

# QUICK-START GUIDE

As used with *Thinklogical's™ Velocitykvm-5 and the Velocitykvm-24* Video Extension Systems

# router VX40 KVM Matrix Switch

Powered by  
MRTS Technology

The VX40 Router Critical Hardware Alarms: (Located at the top, left rear of the unit.)

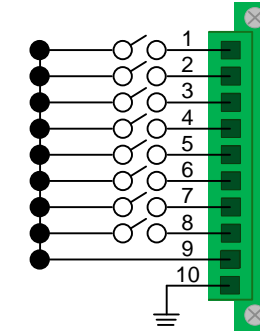

- POWER SUPPLY 1 (LEFT): Fan failure, temperature spikes, DC voltage and/or current out of range, AC power input interruption and module removed
- POWER SUPPLY 2 (RIGHT): Fan failure, temperature spikes, DC voltage and/or current out of range, AC power input interruption and module removed
- FANS: Individual fan monitoring
- TEMPERATURE WARNING: Chassis over temperature, multiple sensors
- TEMPERATURE SHUTDOWN: Chassis over temperature causing shutdown
- CPU: Card failure (Only with a redundant card)
- INPUT/OUTPUT CARDS: SFP+ failure, laser output fault
- ANY OF THE ABOVE
- COMMON GROUND

## Single-Head, Single-Link RGB/KVM Source

**STEP 5:** Connect the DVI/RGB IN cable from the CPU to the VelocityKVM Transmitter. Connect the DVI/RGB OUT cable from the Transmitter to the local monitor.

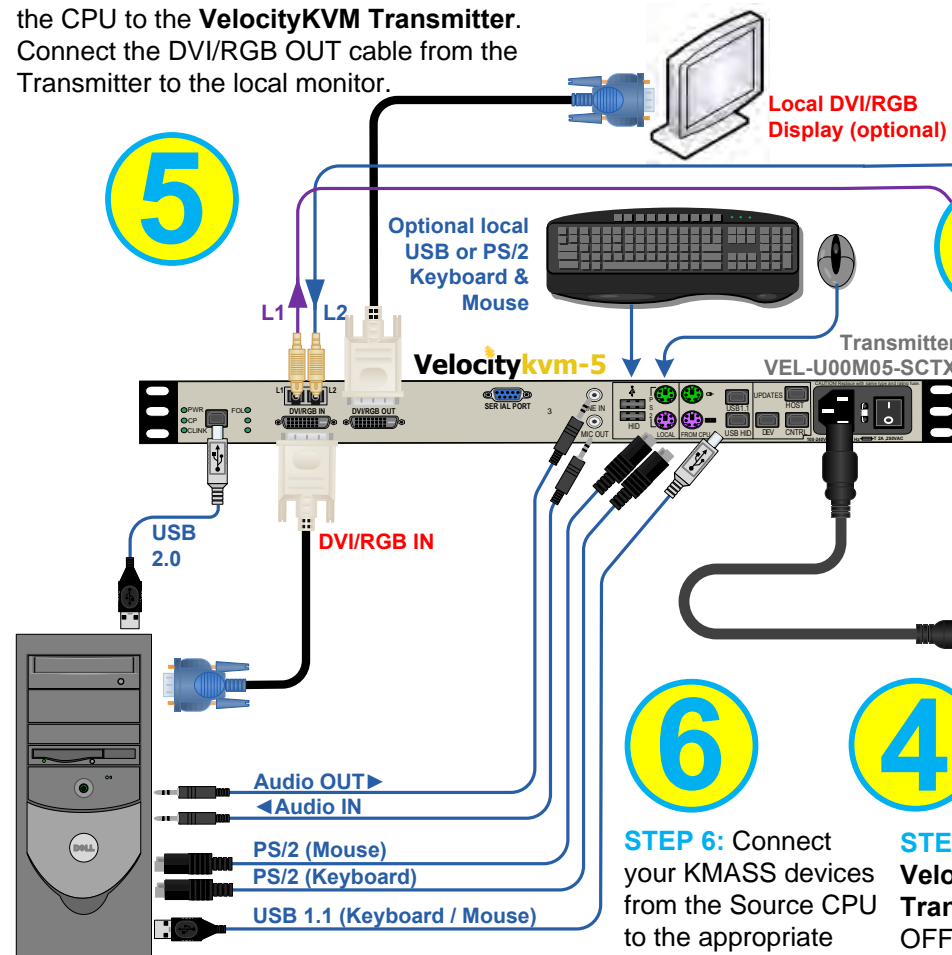

**STEP 3:** Connect your VelocityKVM Transmitter to the VX160 using multi-mode fiber-optic cables (up to 1000 meters). Connect L1 to any Upstream Receive Port and L2 to the same numbered Upstream Transmit Port. (See the Digital Crosspoint Switch detail diagram, below.)

**STEP 8:** (Final step) Connect both supplied AC Power Cords (PWR-000006-R) to the receptacles located on the VX40's power supplies. Plug each one into a standard AC source. Verify that all system functions are operating properly.

Thinklogical's™ VX40 KVM Matrix Switch features redundant Power Supplies and Controller Modules for uninterrupted performance, even during system reconfiguration, updates or debug. The VX40 remains fully functional with only one Power Supply installed or with one Controller activated.

**NOTE:** When using a single Controller, the module on the left (Primary) must be used.\*

## Single-Head, Single-Link RGB/KVM Destinations

**STEP 2:** Ensure that the VelocityKVM Receiver's ON/OFF switch is in the OFF (0) position. Depending on your configuration, connect your desktop devices (monitors, keyboard, mouse, etc.) to the Receiver using standard cables as shown in the example below. Turn all the devices ON. Insert the AC power cord into the Receiver and plug it into a standard AC source. Turn the unit ON.

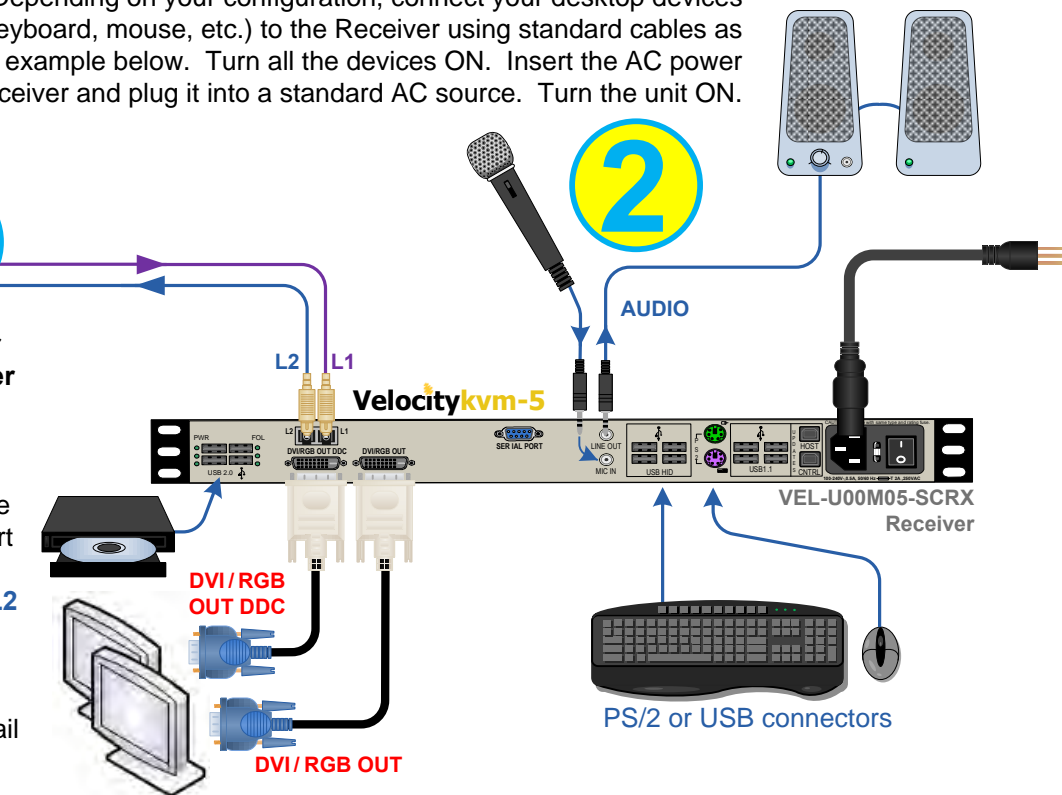

**STEP 1:** Connect your VelocityKVM Receiver to the VX160 using multi-mode fiber-optic cables (up to 1000 meters). Connect cable L1 to any Transmit Port on any Downstream card. Connect cable L2 to the same numbered Downstream Receive Port. (See the Digital Crosspoint Switch detail diagram, below.)

## Single-Link, DVI 2 Display/KVM Source

**STEP 5:** Connect the DVI IN cables from the CPU to the VelocityKVM Transmitter and the DVI OUT cable(s) from the transmitter to the local monitor(s).

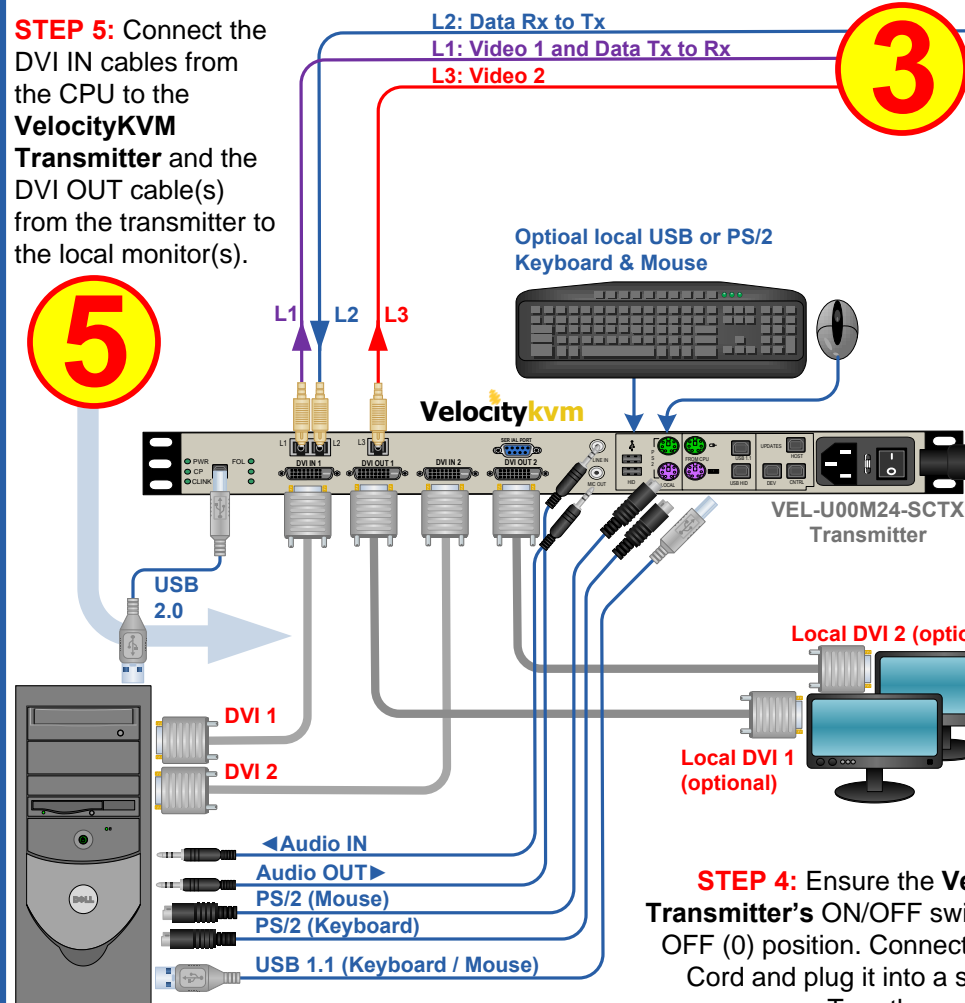

**STEP 3:** Connect your VelocityKVM Transmitter to the VX40 using multi-mode fiber-optic cables (up to 1000 meters). Connect cable L1 to any Upstream Receive Port and cable L2 to the same numbered Upstream Transmit Port. Connect L3 to any Upstream Receive Port. (See the Digital Crosspoint Switch detail diagram, right.)

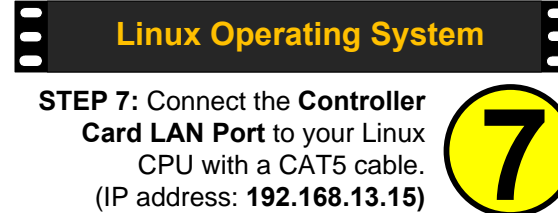

**STEP 7:** Connect the Controller Card LAN Port to your Linux CPU with a CAT5 cable. (IP address: 192.168.13.15)

## Single-Link, DVI 2 Display/KVM Destinations

**STEP 1:** Connect your VelocityKVM Receiver to the VX40 using multi-mode fiber-optic cables (up to 1000 meters). Connect L1 to any Downstream Transmit Ports and L2 to the same numbered Downstream Receive Port as shown. Connect L3 to any Downstream Transmit Port. (See the Digital Crosspoint Switch detail diagram, left.)

**STEP 2:** Ensure that the VelocityKVM Receiver's ON/OFF switch is in the OFF (0) position. Depending on your configuration, connect your desktop devices (monitors, keyboard, mouse, etc.) to the Receiver using standard cables as shown in the example below. Turn all the devices ON. Insert the AC power cord into the Receiver and plug it into a standard AC source. Turn the unit ON.

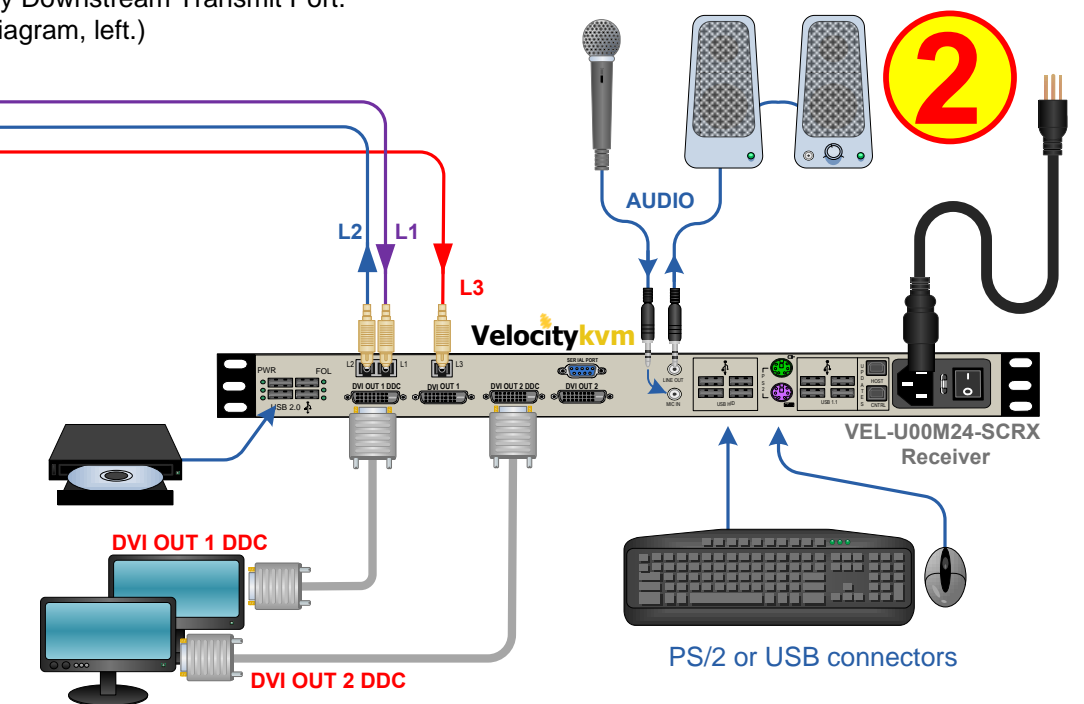

### Digital Crosspoint Switch

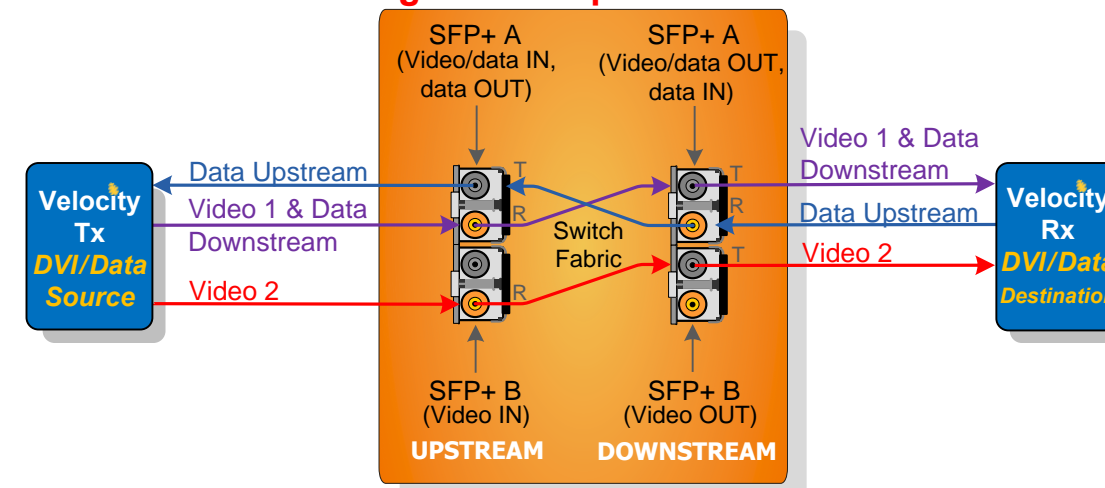

**STEP 6:** Connect your USB, PS/2 and Audio sources to the VelocityKVM Transmitter's inputs.

**STEP 4:** Ensure the VelocityKVM Transmitter's ON/OFF switch is in the OFF (0) position. Connect the Power Cord and plug it into a standard AC source. Turn the switch ON (1).

**thinklogical™**

PHONE: 1-800-291-3211  
WEBSITE: www.thinklogical.com  
EMAIL: support@thinklogical.com

Visit us online at [www.thinklogical.com](http://www.thinklogical.com) for more product information, current updates and the complete line of Thinklogical™ products.