

QUICK-START GUIDE

As used with *Thinklogical's™ Velocitydvi Video Extension System-3 A/V+, Velocityrgb Video Extension System-9 and the Velocitykvm Fiber Extension System-4*

router VX160 KVM Matrix Switch

Powered by
MRTS Technology

The **VX160 Router Critical Hardware Alarms:** (Located at the top, left rear of the unit.)

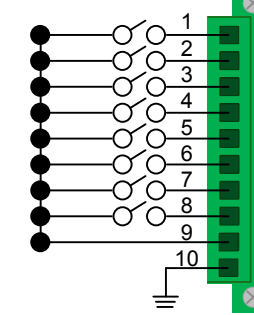

- POWER SUPPLY 1 (LEFT):** Fan failure, temperature spikes, DC voltage and/or current out of range, AC power input interruption and module removed
- POWER SUPPLY 2 (RIGHT):** Fan failure, temperature spikes, DC voltage and/or current out of range, AC power input interruption and module removed
- FANS:** Individual fan monitoring
- TEMPERATURE WARNING:** Chassis over temperature, multiple sensors
- TEMPERATURE SHUTDOWN:** Chassis over temperature causing shutdown
- CPU:** Card failure (Only with a redundant card)
- INPUT/OUTPUT CARDS:** SFP+ failure, laser output fault
- ANY OF THE ABOVE COMMON GROUND**

STEP 4: Connect your DVI cable from the Source CPU to the DVI from CPU Transmitter port. If desired, connect a local video device to the Transmitter's DVI to Local Display port.

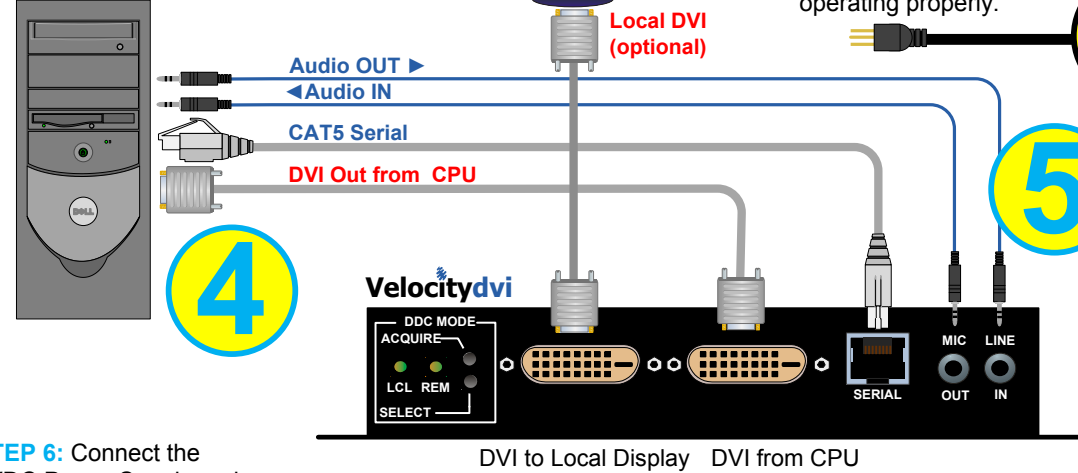

STEP 9: Connect both supplied AC Power Cords (PWR-000056-R) to the receptacles located on the VX160's power supplies. Plug each of them into a standard AC source. Verify that all system functions are operating properly.

STEP 5: Connect your Audio and Serial devices from the Source CPU to the appropriate Transmitter ports using standard cables.

STEP 6: Connect the 5VDC Power Supply and plug it into a standard AC source.

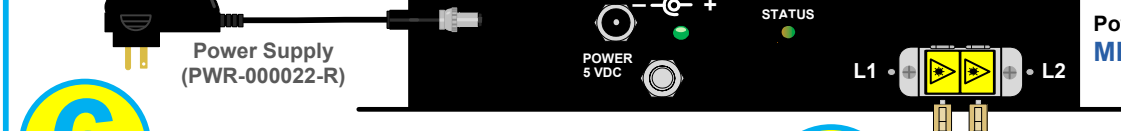

Single-Link DVI Source

STEP 7: Connect your Velocity Transmitter to a VX160 Upstream Card using multi-mode fiber-optic cables (up to 1000 meters). Connect L1 to any Receive Port and L2 to the same numbered Transmit Port. (See the Digital Crosspoint Switch detail diagram, below.)



STEP 7: Connect your Velocity Transmitter to a VX160 Upstream Card using multi-mode fiber-optic cables (up to 1000 meters). Connect L1 to any Receive Port and L2 to the same numbered Transmit Port. (See the Digital Crosspoint Switch detail diagram, below.)

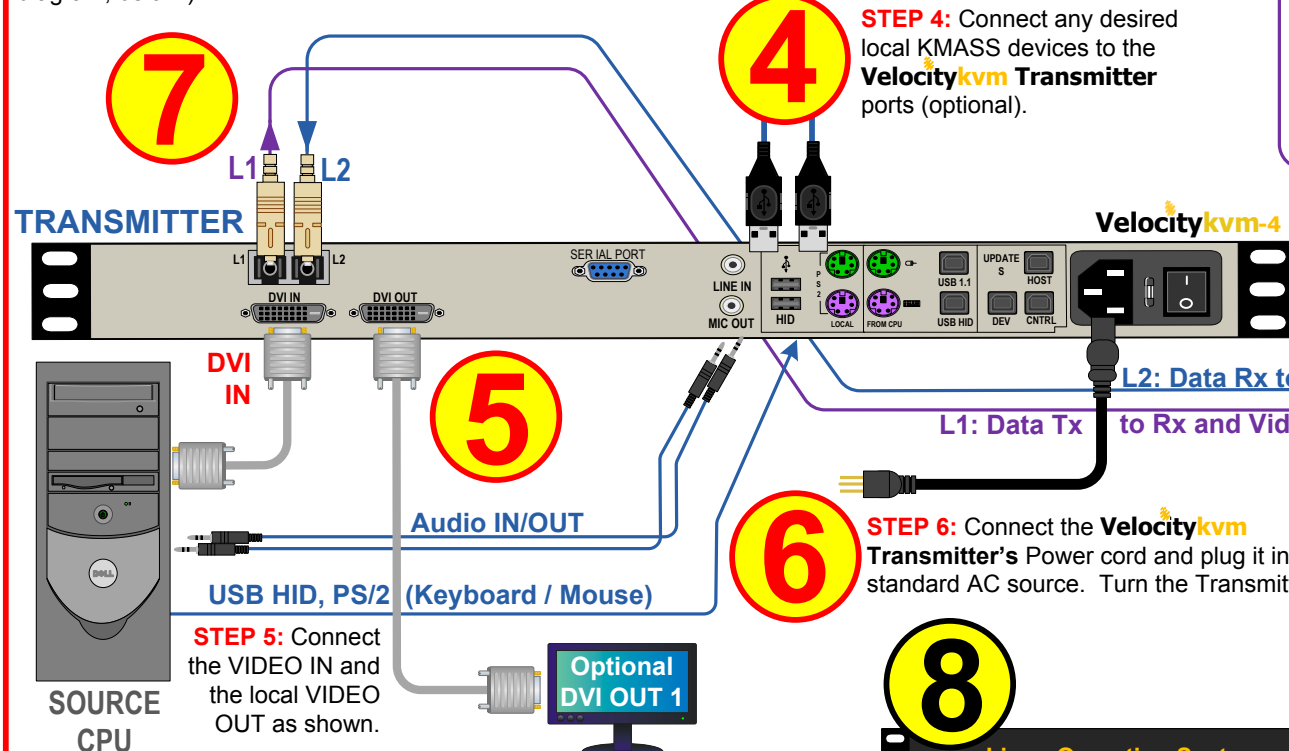

Single Head DVI KVM Source

Single Head RGB Source

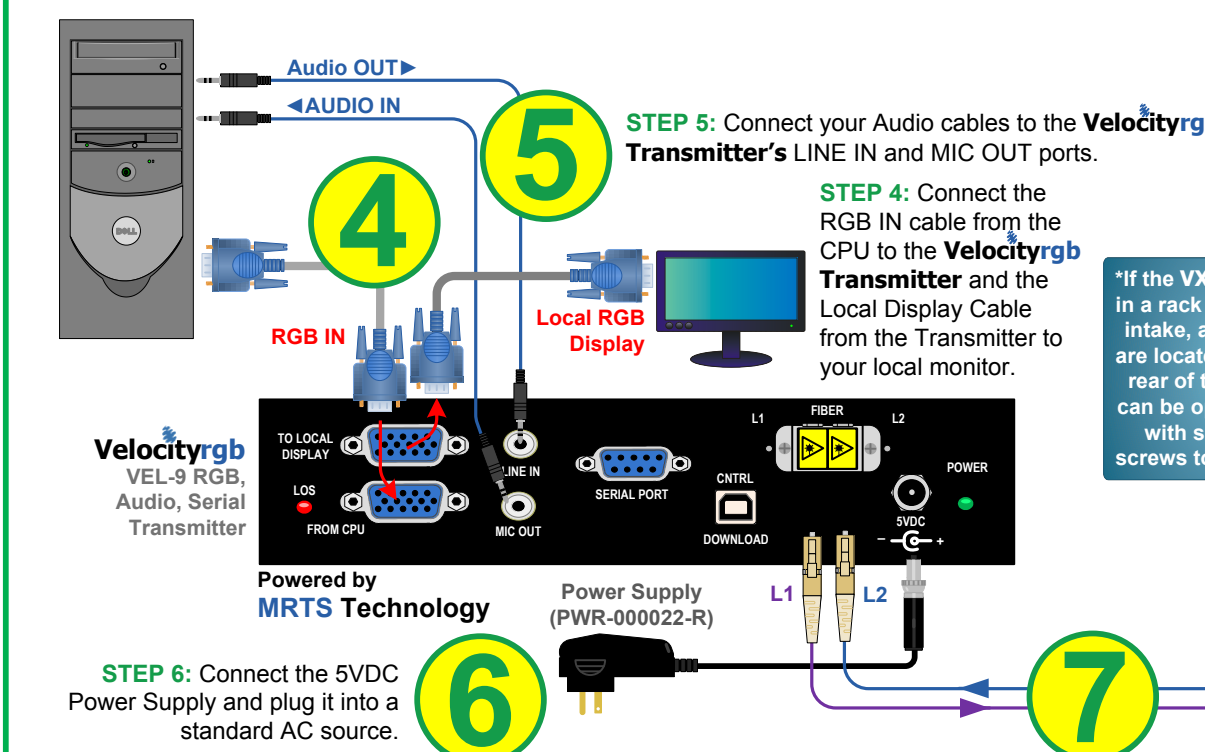

STEP 6: Connect the 5VDC Power Supply and plug it into a standard AC source.

STEP 7: Connect your Velocity Transmitter to a VX160 Upstream Card using multi-mode fiber-optic cables (up to 1000 meters). Connect L1 to any Receive Port and L2 to the same numbered Transmit Port. (See the Digital Crosspoint Switch detail diagram, right.)

Thinklogical's™ VX160 KVM Matrix Switch features redundant Power Supplies and Fail-Over Controller Modules for uninterrupted performance, even during system reconfiguration, updates or debug. The VX160 remains fully functional with only one Power Supply installed or with one Controller activated. **NOTE:** When using a single Controller, the module on the left must be used.

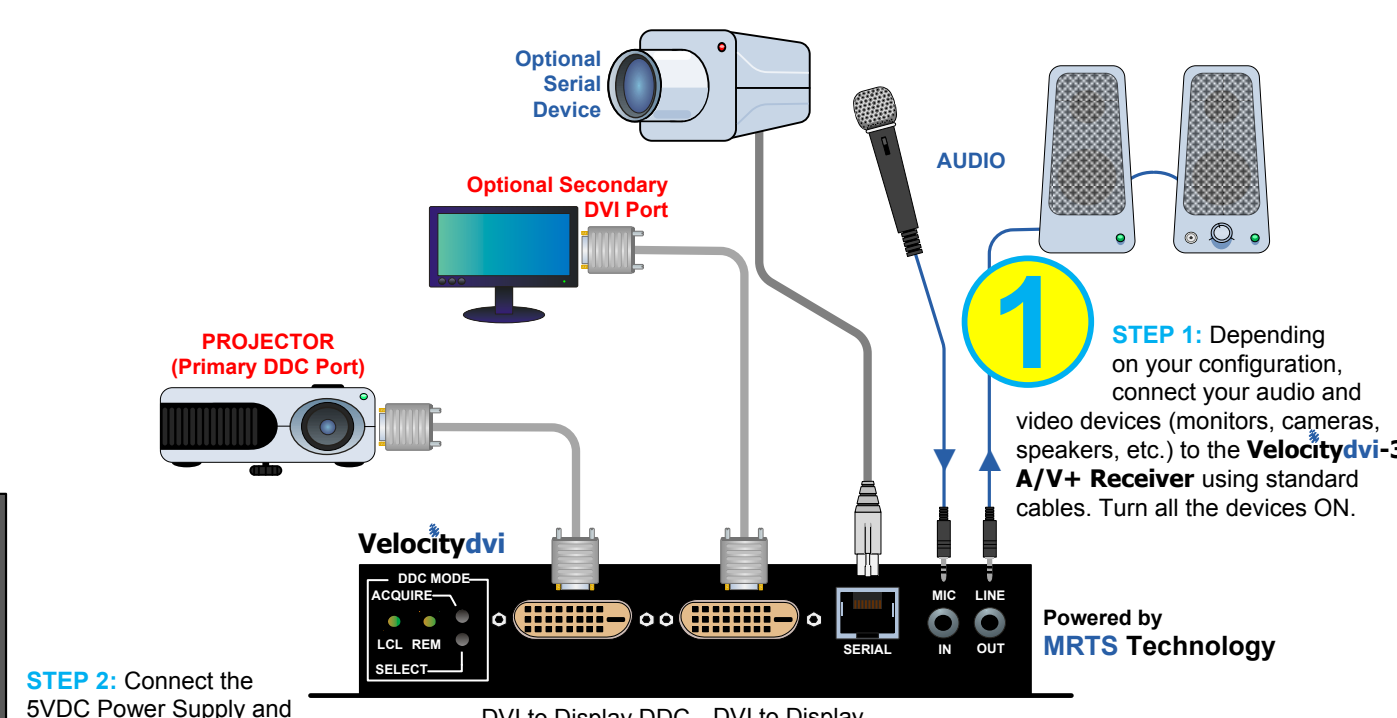
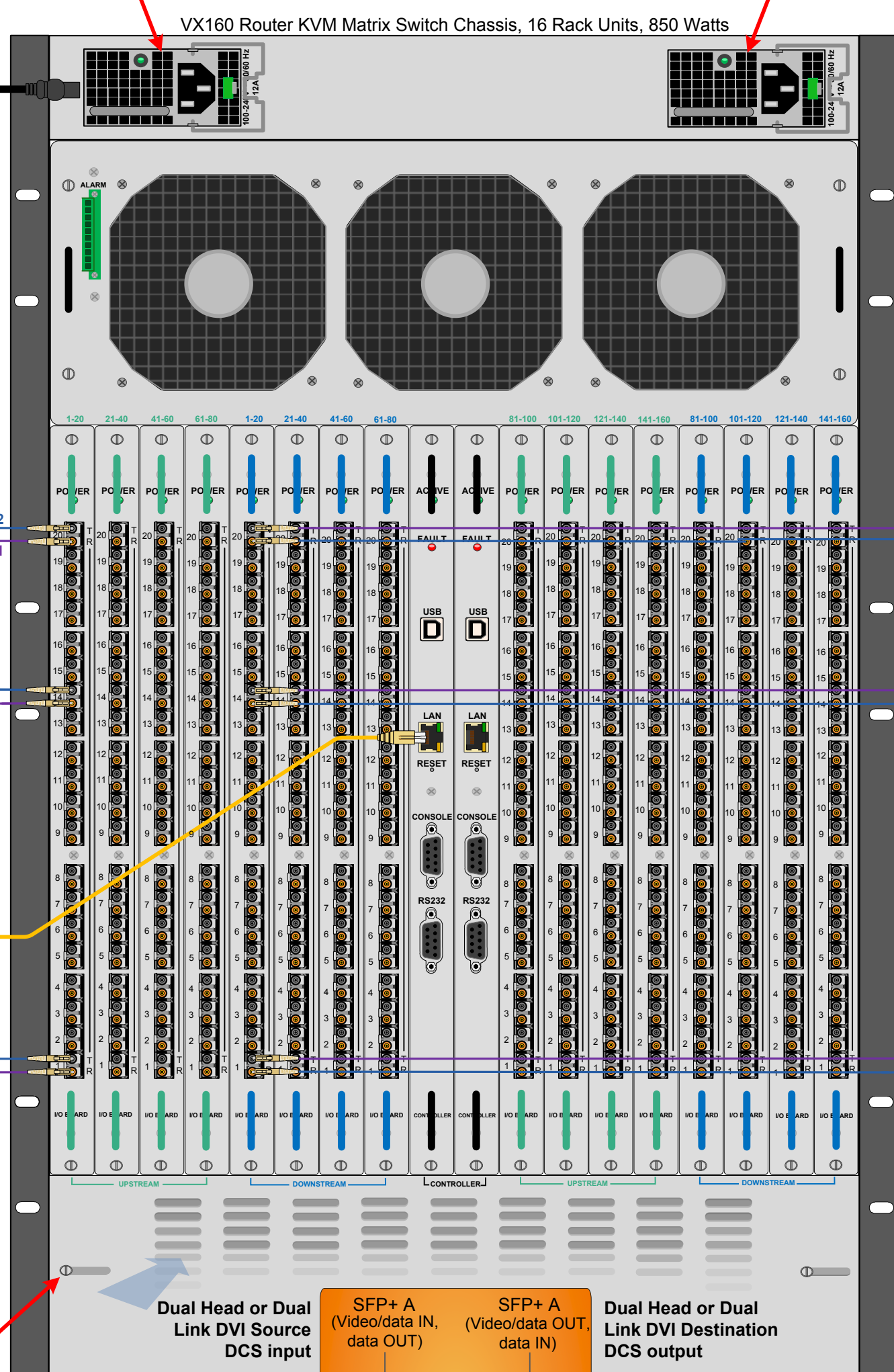

STEP 2: Connect the 5VDC Power Supply and plug it into a standard AC source.

STEP 3: Connect your Velocity Receiver to a VX160 Downstream Card using multi-mode fiber-optic cables (up to 1000 meters). Connect L1 to any Transmit Port and L2 to the same numbered Receive Port. (See the Digital Crosspoint Switch detail diagram, below.)

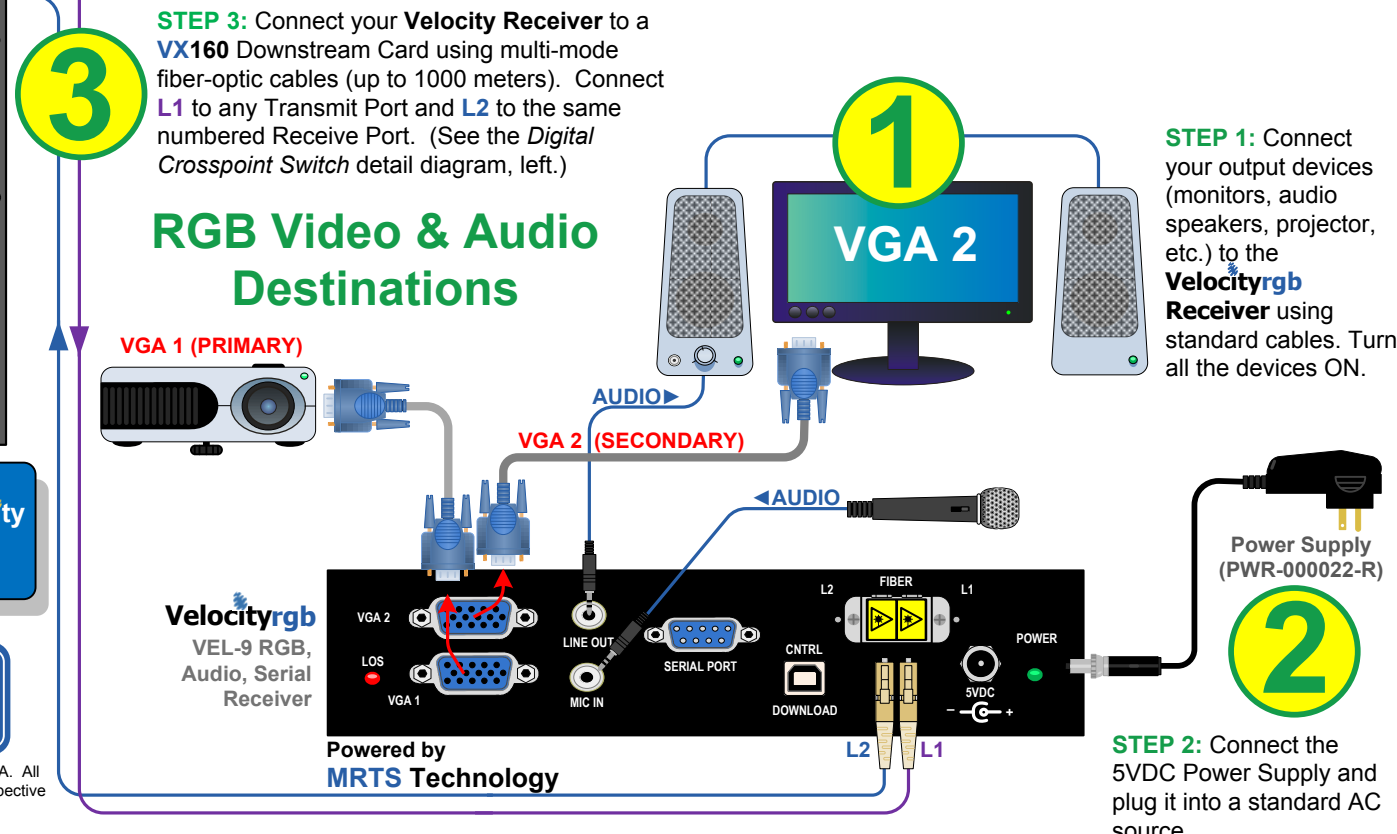
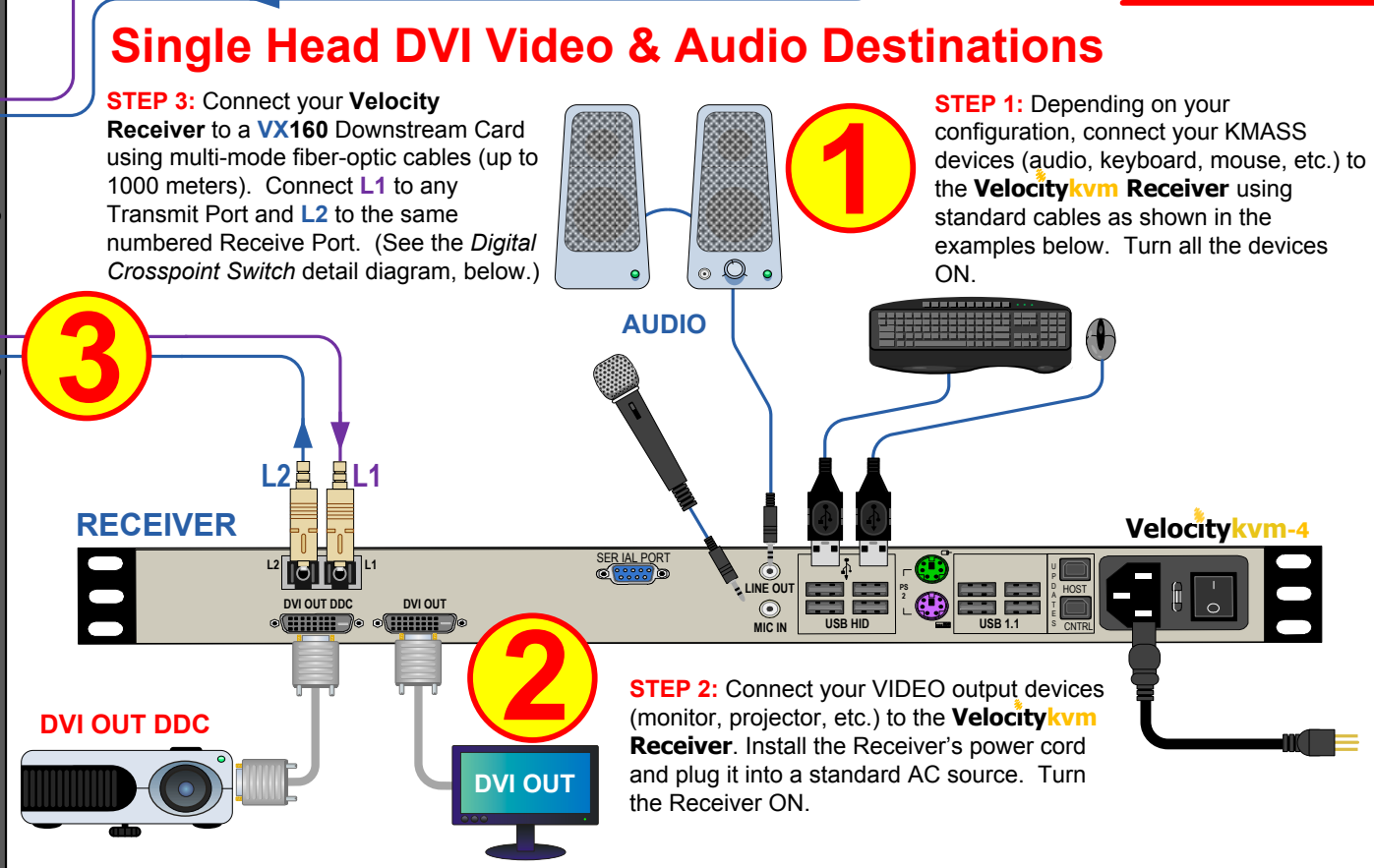

STEP 3: Connect your Velocity Receiver to a VX160 Downstream Card using multi-mode fiber-optic cables (up to 1000 meters). Connect L1 to any Transmit Port and L2 to the same numbered Receive Port. (See the Digital Crosspoint Switch detail diagram, left.)

STEP 1: Connect your output devices (monitors, audio speakers, projector, etc.) to the Velocityrgb Receiver using standard cables. Turn all the devices ON.

STEP 2: Connect the 5VDC Power Supply and plug it into a standard AC source.

PHONE: (800) 291-3211
WEBSITE: www.thinklogical.com
EMAIL: support@thinklogical.com

Copyright © 2009. All rights reserved. Printed in the U.S.A. All trademarks and service marks are the property of their respective owners.