

QUICK-START GUIDE

As used with **Thinklogical's™ Velocitydvi-3 A/V+ Video Extension System** and the **Velocitykvm-24 Video Extension System**

STEP 4: Connect your DVI cable from the Source CPU to the Velocitydvi-3 A/V+ Transmitter's DVI from CPU port. If desired, connect a local video device to the Transmitter's DVI to Local Display port.

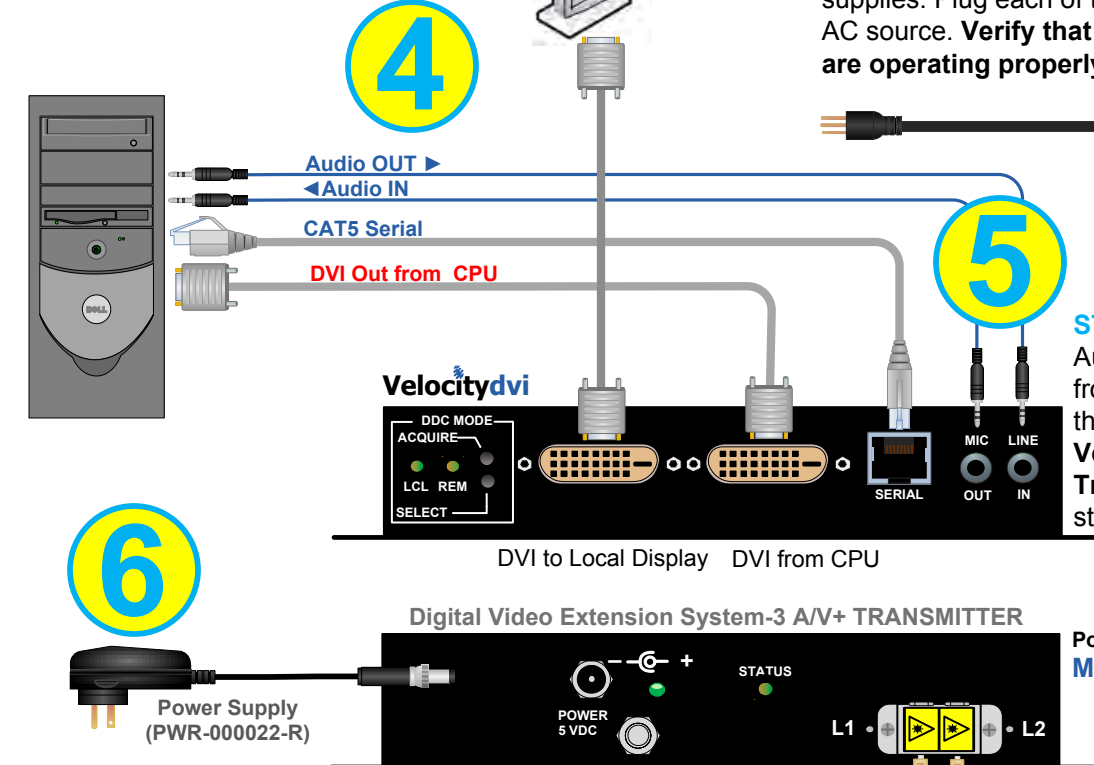

STEP 6: Connect the 5VDC Power Supply and plug it into a standard AC source.

Single-Link DVI Video, Serial & Audio Source

STEP 8: Connect the Controller Card LAN Port to your Linux CPU with a CAT5 cable. (IP address: 192.168.13.15)

Dual Head DVI KVM Source

STEP 4: Connect the DVI IN cables from the CPU to the Velocitykvm-24 Transmitter and the DVI OUT cable(s) from the transmitter to the local monitor(s).

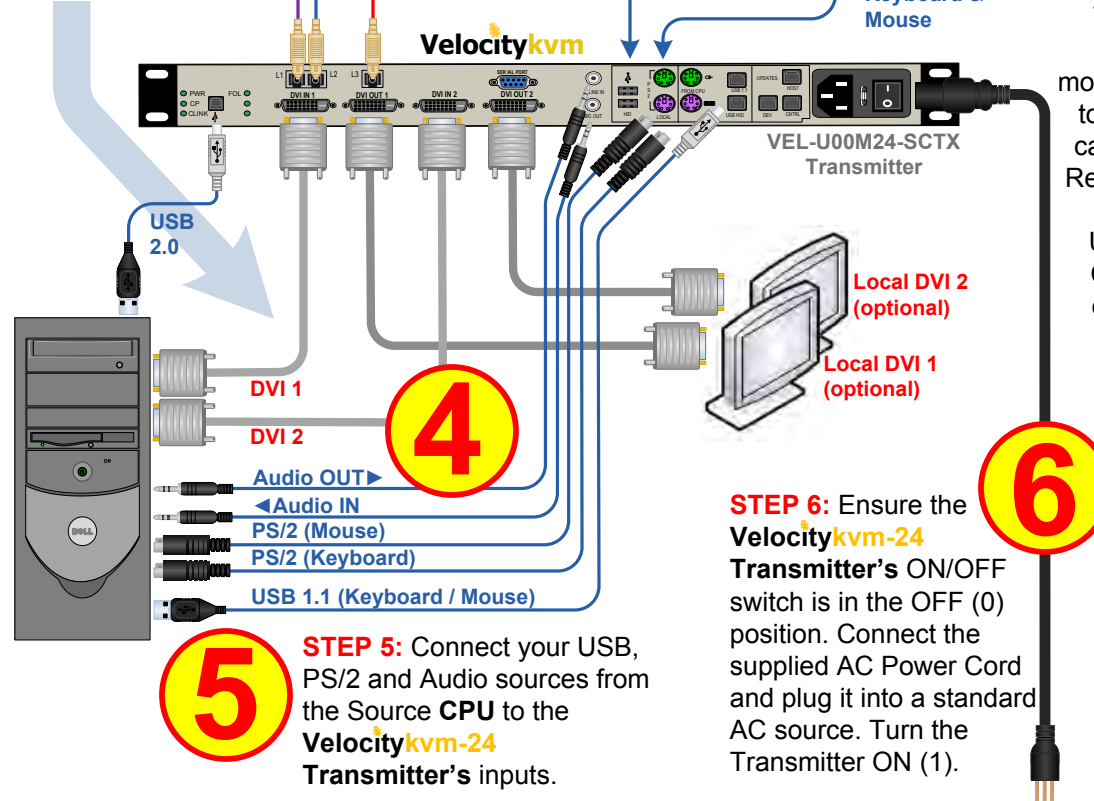

STEP 5: Connect your USB, PS/2 and Audio sources from the Source CPU to the Velocitykvm-24 Transmitter's inputs.

thinklogical™

PHONE: (800) 291-3211
WEBSITE: www.thinklogical.com
EMAIL: support@thinklogical.com

router VX160 KVM Matrix Switch

Powered by
MRTS Technology

VX160 Router KVM Matrix Switch Chassis, 16 Rack Units, 850 Watts

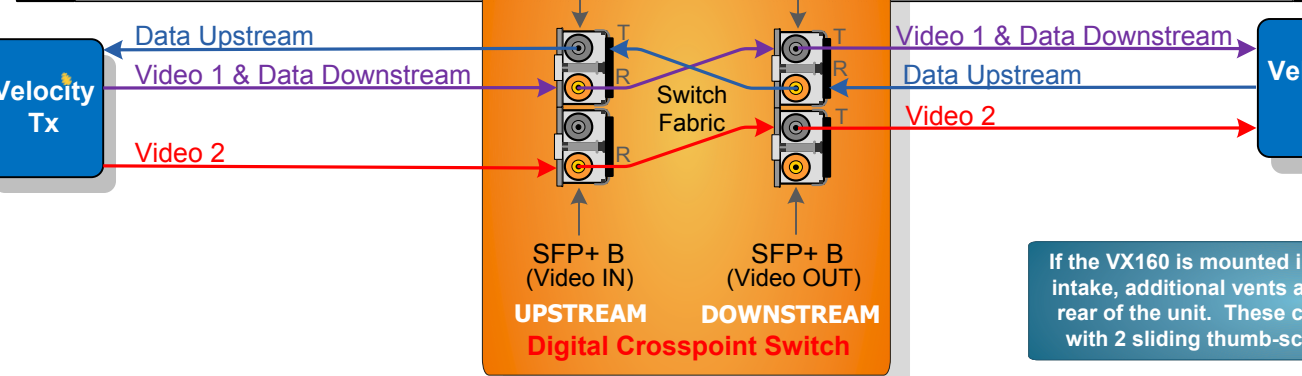
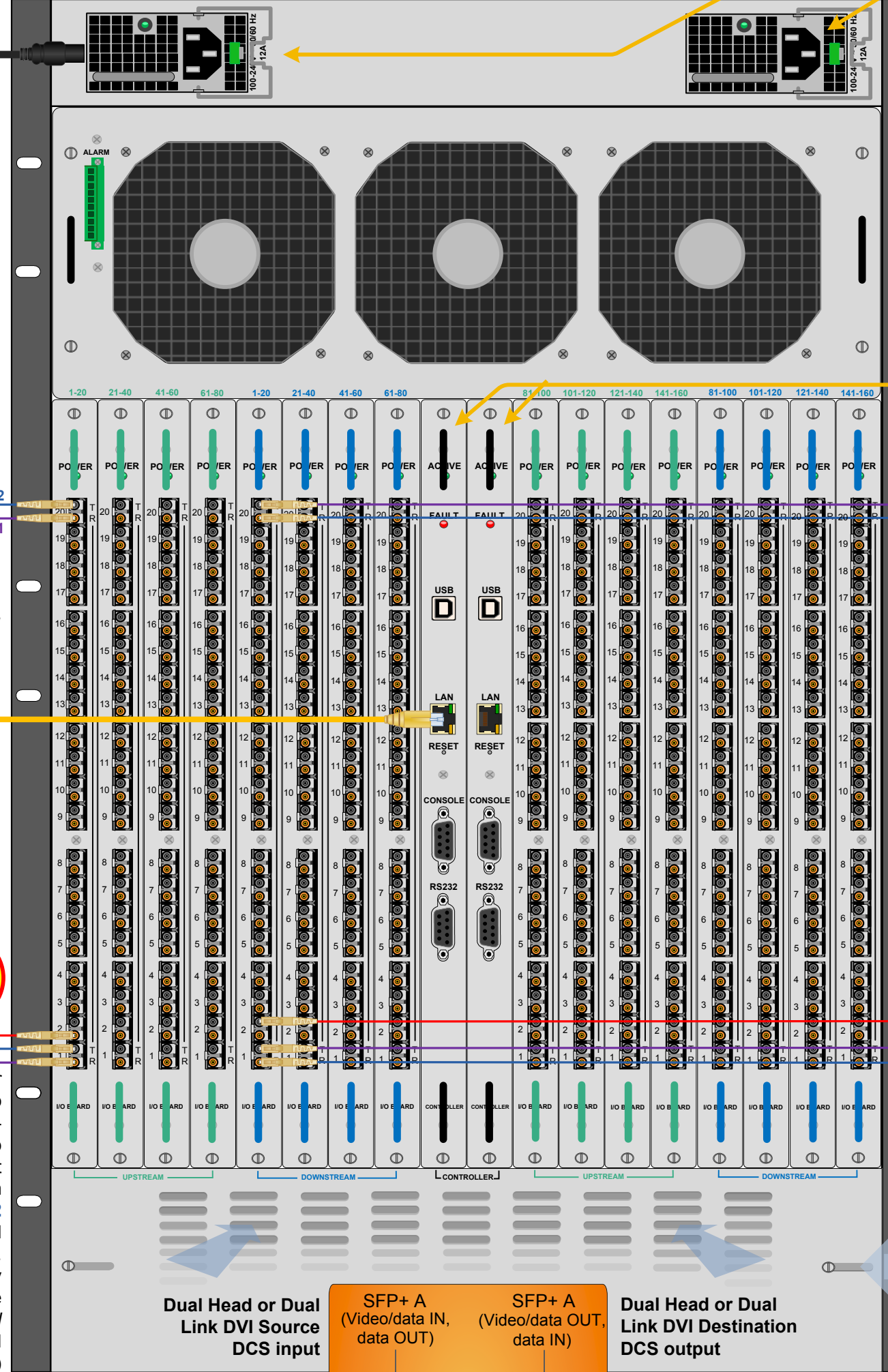

The VX160 Router Critical Hardware Alarms: (Located at the top, left rear of the unit.)

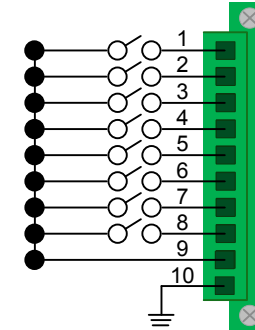

- POWER SUPPLY 1 (LEFT): Fan failure, temperature spikes, DC voltage and/or current out of range, AC power input interruption and module removed
- POWER SUPPLY 2 (RIGHT): Fan failure, temperature spikes, DC voltage and/or current out of range, AC power input interruption and module removed
- FANS: Individual fan monitoring
- TEMPERATURE WARNING: Chassis over temperature, multiple sensors
- TEMPERATURE SHUTDOWN: Chassis over temperature causing shutdown
- CPU: Card failure (Only with a redundant card)
- INPUT/OUTPUT CARDS: SFP+ failure, laser output fault
- ANY OF THE ABOVE
- COMMON
- GROUND

Thinklogical's™ VX160 KVM Matrix Switch features redundant Power Supplies and Fail-Over Controller Modules for uninterrupted performance, even during system reconfiguration, updates or debug. The VX160 remains fully functional with only one Power Supply installed or with one Controller activated.

NOTE: When using a single Controller, the module on the left must be used.

- CONTENTS**
Upon receiving your Thinklogical™ VX160 KVM Matrix Switch you should find the following items:
- VX160 Chassis & Cards
 - LC Duplex Bulkhead with Flange
 - 15' CAT5 Cable (1)
 - AC Power Cord (2)
 - Product Manual CD

Single-Link DVI Video, Serial & Audio Destinations

STEP 3: Connect your Velocity Receiver to a VX160 Downstream Card using multi-mode fiber-optic cables (up to 1000 meters). Connect L1 to any Transmit Port and L2 to the same numbered Receive Port. (See the Digital Crosspoint Switch detail diagram, below.)

STEP 2: Connect the 5VDC Power Supply and plug it into a standard AC source.

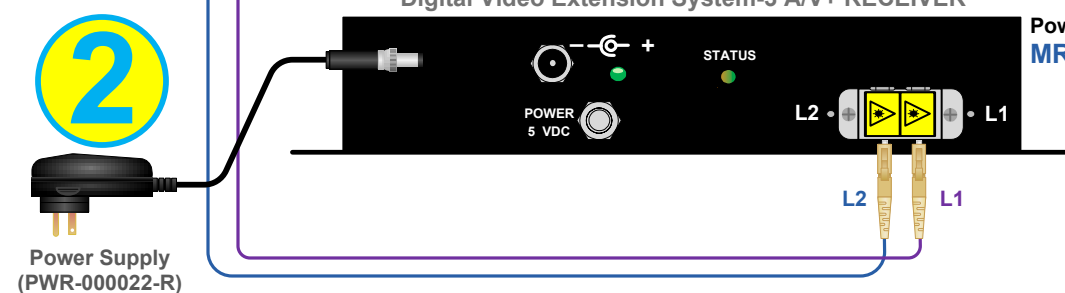

Dual Head DVI KVM Destinations

STEP 3: Connect your Velocity Receiver to the VX160 using multi-mode fiber-optic cables (up to 1000 meters). Connect L1 to any Downstream Transmit Port and L2 to the same numbered Downstream Receive Port. Connect L3 to any other Downstream Transmit Port. (See the Digital Crosspoint Switch detail diagram, left.)

STEP 1: Depending on your configuration, connect your desktop devices (monitors, keyboard, mouse, etc.) to the Velocitykvm-24 Receiver using standard cables, as shown. Turn all the devices ON.

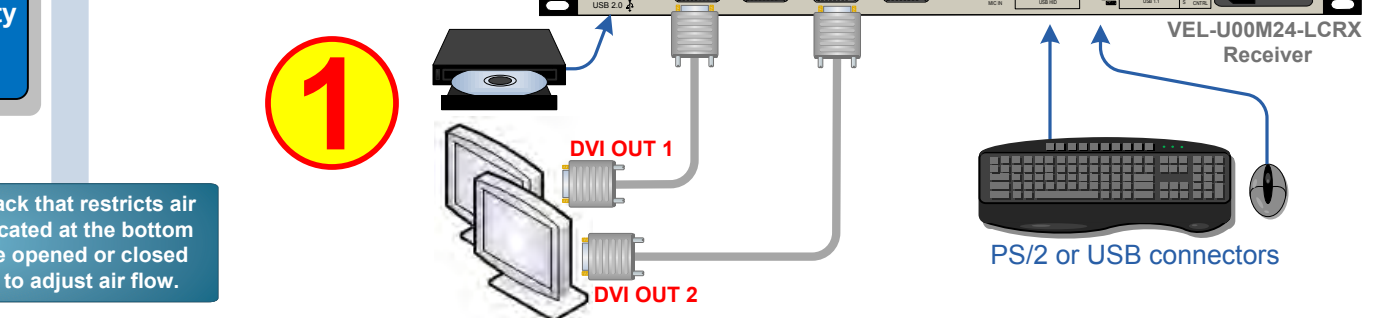

If the VX160 is mounted in a rack that restricts air intake, additional vents are located at the bottom rear of the unit. These can be opened or closed with 2 sliding thumb-screws to adjust air flow.