

PDU 4/4

QUICK START GUIDE

Thinklogical's™ PDU 4/4 Power Distribution Unit is an AC Power Switch that provides the ability to remotely control the power to up to eight devices per unit. It gives system administrators the capability to restart a "locked up" network device from an RS-232 Serial Port. The PDU 4/4 provides eight individually-controlled AC power outlets that are switched off and on as desired. The PDU 4/4 communicates with its control terminal using a serial interface. The easy-to-use PDU 4/4 provides control to all devices with simple commands to turn Power Off or On to reboot any one port, multiple ports, port groups or all devices. Power restarts can be sequenced using programmed time delays to minimize surge or allow drive spin-up time. Rear panel LEDs display the status of each port.

Your configuration can be easily expanded with a serial cable for each PDU 4/4 unit added. A single serial interface integrates the control of all PDU 4/4s in your application. Up to sixteen PDU 4/4s can be cascaded together to control multiple systems from one common user interface. Each PDU 4/4 utilizes two banks of four outlets. Each outlet individually switches up to 10 Amperes maximum with each bank rated at 15 Amperes total. The PDU 4/4 is designed for rack mounting (1U) or as a desktop device.

Each PDU4/4 system includes the following features:

- Eight individually-controlled AC power outlets
- Dual 15 Amp (max) circuits, four outlets per circuit
- Redundant DC power supplies for built-in I/O and control circuits
- Individually programmable Reboot Time Delay on each outlet
- Solid state zero-crossing relays to minimize power spikes
- Easily expandable configuration
- Password Security
- User-definable Port Names and Port Groups
- Front panel display for easy system set up and configuration
- Current monitoring of each port to determine if connected unit turns on.
- Software updates available on

ftp.thinklogical.com

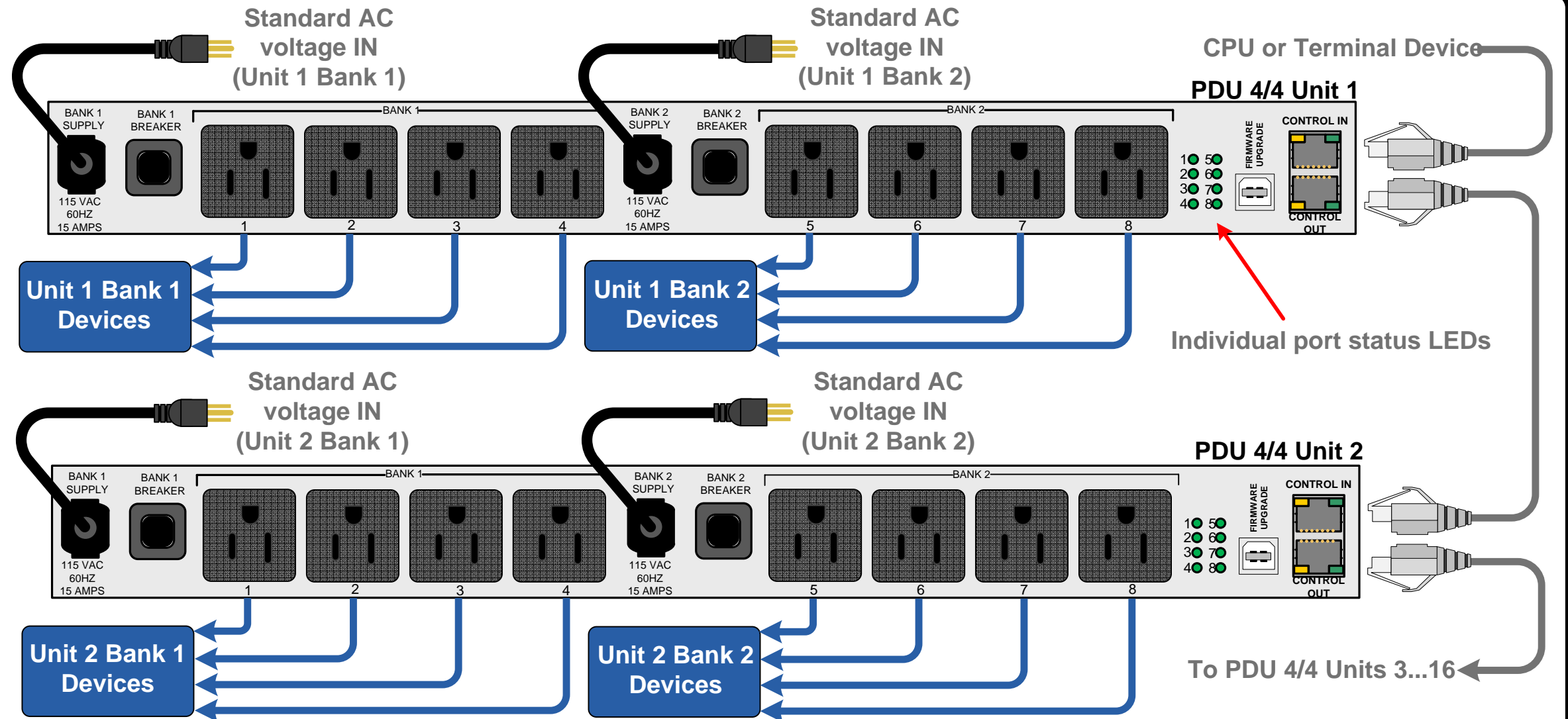

Once connected to the PDU 4/4's **CONTROL IN** serial port, the following access and programming commands may be used:

Press 'Enter' on the keyboard to establish communication. Your display should show "**Password:**" The factory-set password is **pass** and may be changed by the System Administrator. When Logged In, the command prompt will show "**PDU 4/4>**". Commands are executed from the Serial Terminal.

on The on command is used to turn on a port or group of ports. Any port may be referred to by either Port Numbers or Port Names. All ports with identical port names will be turned on together (as a Port Group).

off The off command is used to turn off a port or group of ports.

reboot The Reboot Output command is used to 'reboot' a server or device by cycling power to a port or ports. Refer to the user's manual for further commands.

The front-panel LCD display should be visible and accessible for system setup. The front panel buttons are used to configure the unit and to review existing PDU 4/4 configurations.

LCD System Information & Programming



LCD Navigation

thinklogical™

PHONE: (800) 291-3211
WEBSITE: www.thinklogical.com
EMAIL: support@thinklogical.com

Visit us online at www.thinklogical.com for more product information, current updates and the complete line of Thinklogical™ products.