

Camera Fiber-Link Digital Camera Extension System

PRODUCT & INSTALLATION MANUAL

For the CFL-3000, CFL-4000, CFL-5000 and CFL-6000 Models



thinklogical[™]
The Future of Access and Control

100 Washington Street
Milford, Connecticut 06460 U.S.A.

Telephone (203) 647-8700
Fax (203) 783-9949
www.thinklogical.com

Copyright Notice

Copyright © 2009. All rights reserved. Printed in the U.S.A.

Thinklogical[™], a subsidiary of Logical Solutions, Incorporated
100 Washington Street
Milford, Connecticut 06460 U.S.A.
Telephone (203) 647-8700

All trademarks and service marks are property of their respective owners.

Subject: Camera Fiber-Link Video Extension System-3000, -4000, -5000, -6000
Revision: D, September 2009

Table of Contents

1. Introduction	1
1.1 The Logical Solution.....	1
1.2 The Camera Fiber-Link System	1
1.2.1. Models Available from <i>Thinklogical</i> [™]	3
1.2.2. Increased Security	5
1.2.3. LASER Protection	5
2. System Features	6
2.1. General System Features.....	6
2.2. Hardware Features.....	7
2.2.1. CFL-3000	7
2.2.2. CFL-4000	8
2.2.3. CFL-5000	9
2.2.4. CFL-6000	10
2.2.5. Power Enhancement Kit (Optional).....	10
2.2.6. DIN Rails (Optional)	10
2.3. Technical Specifications	11
3. Connecting the Camera Fiber-Link	14
3.1 Types of Connections.....	14
3.1.1. Fiber Cable.....	14
3.1.2. Digital Video Camera Side	14
3.1.3. Digital Video Frame Grabber Side	14
3.1.4. Serial Port	14
3.1.5. Camera Control.....	16
3.2. AC Power	16
3.2.1. Standard Version: 5V-12V.....	16
3.2.2. Industrial Version: 12V-24V.....	17
4. Order of Installation Events	17
4.1 CFL-3000	18
4.2 CFL-4000	19
4.3 CFL-5000	20
4.4 CFL-6000	21
5. Regulatory & Safety Compliance	22
5.1 Safety Requirements	22
5.1.1. Symbols Found on the Product	22
5.1.2. Product Serial Number	22
5.1.3. Connection to the Product	22
5.2 Regulatory Compliance	22
5.2.1. North America	23
5.2.2. Australia & New Zealand	23
5.2.3. European Union	23
5.2.3.1. Declaration of Conformity	23
5.2.3.2. Standards With Which the Products Comply	24
5.3 Supplementary Information.....	24

6. How to Contact Us	25
6.1 Customer Support.....	25
6.1.1 Website.....	25
6.1.2 Email	26
6.1.3 Telephone.....	26
6.1.4 Fax	26
6.2 Product Support.....	26
6.2.1 Warranty.....	26
Return Authorization	Error! Bookmark not defined.
6.2.3 Our Address	26
 Table 1 Technical Specifications.....	 11
 Figure 1 <i>Thinklogical</i> [™] Camera Fiber-Link and Cabling Application Drawing	 2
Figure 2 Top and side views of CFL-3000 Camera Side and Frame Grabber Side	7
Figure 3 Top and side views of CFL-4000 Camera Side and Frame Grabber Side	8
Figure 4 Top and side views of CFL-5000 Camera Side and Frame Grabber Side	9
Figure 5 Top and side views of CFL-6000 Frame Grabber Side	10
Figure 6 Serial Port (RJ45) Connections	15
Figure 7 5V-12V Power Supply	16
Figure 8 12V-24V Power Supply	17
Figure 9 CFL-3000 Quick Start Diagram.....	18
Figure 10 CFL-4000 Quick Start Diagram	19
Figure 11 CFL-5000 Quick Start Diagram	20
Figure 12 CFL-6000 Quick Start Diagram	21
Figure 13 CFL Mounting Template.....	37
 Appendix A Camera and Frame Grabber Compatibility Chart.....	 28
Appendix B DB9/RJ45 Adapter Pin-outs	34
Appendix C Maximum Distances for Fiber Types.....	35
Appendix D Camera Fiber-Link Mounting Template.....	36

1. Introduction

1.1. The Logical Solution

Process monitoring, machine vision and security applications often require that remote cameras be positioned far from their controlling computers. Long distance image transmission, security and resolution are top priorities in these and many other environments. That's why we've developed the *Thinklogical*[™] Camera Fiber-Link Extension System with the Camera-Link[™] standard for high performance digital cameras and frame grabbers.

1.2. The Camera Fiber-Link System

The Camera Fiber-Link System uses a Camera Side Unit and a Frame Grabber Side Unit that are interconnected by duplex, multi-mode fiber optic cables to allow Camera Link video support up to 350 meters (1150 feet) from the host computer with no loss of signal or resolution and without the use of amplifiers or repeaters of any kind. With industrial enhancements such as a threaded screw-lock input for standard 5V-12V input power, or for our 12V-24V input power, designed for rugged industrial environments, the Camera Fiber-Link System is ideal for any application.



Conventions Used In This Manual

As you read this manual you will notice certain conventions that bring your attention to important information. These are **Notes** and **Warnings**. Examples are shown below.



Note: Important Notes appear in blue text preceded by a yellow exclamation point symbol, like this.

A note is meant to call the reader's attention to helpful information at a point in the text that is relevant to the subject being discussed.



Warning! Warnings appear in red text, followed by blue text, and preceded by a red stop sign, like this.

A warning is meant to call the reader's attention to critical information at a point in the text that is relevant to the subject being discussed.

Before starting any procedure, please read the instructions thoroughly before proceeding.

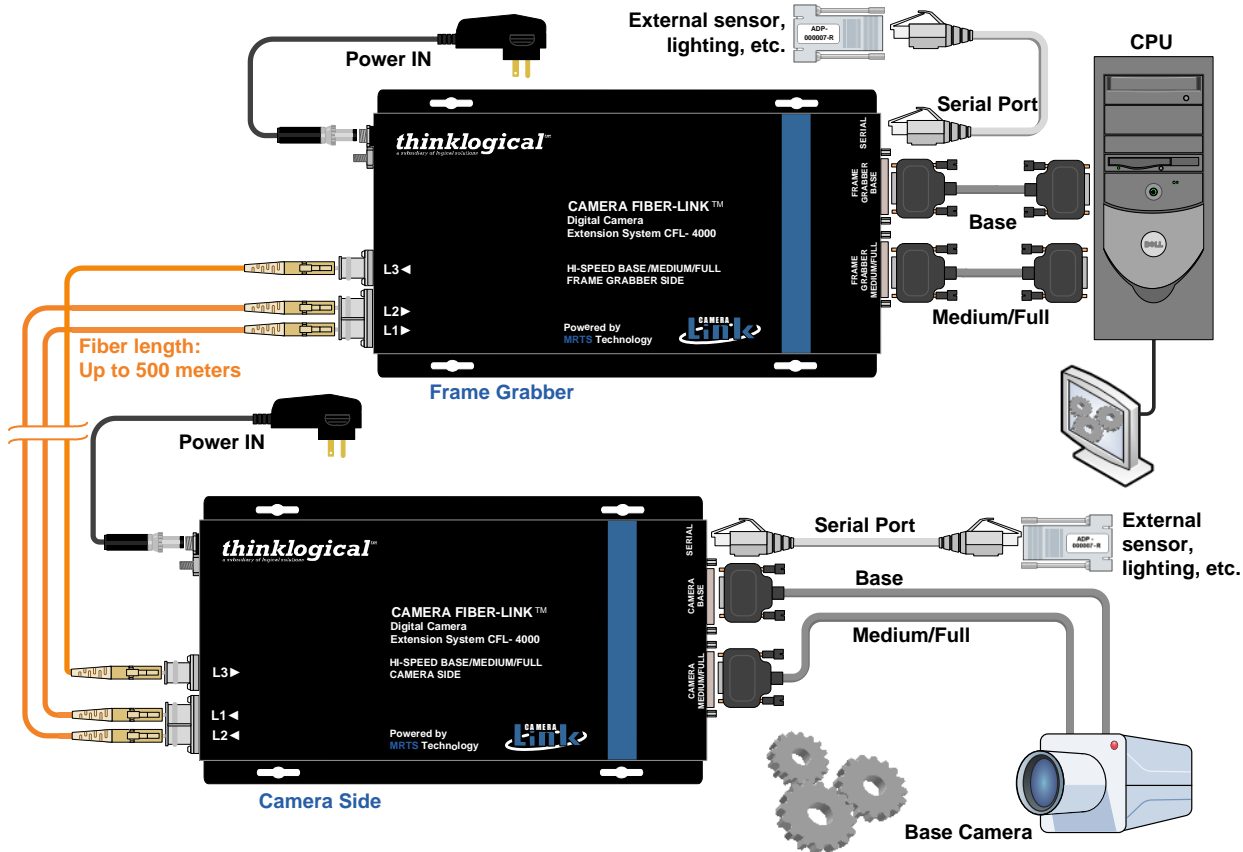

CABLING: 50/125 um or 62.5/125 um, LC, SC or ST-type connector
 CBL-000001-002M (CAT5)
 CBL-000007-002M (MDR-26 M to M)
 PWR-00022-R (AC to DC Converter-Standard)
 PWR-00033-R (AC to DC Converter-Industrial)

Figure 1: Thinklogical™ Camera Fiber-Link and Cabling Application Drawing

The Camera Fiber-Link System from Thinklogical™ allows the placement of a digital camera up to 350 meters (1150 feet) from the controlling computer without loss of resolution. Traditional copper cables are limited to 10 meters (32.81 feet) in such applications. Each Base or Medium/Full Camera Fiber-Link System uses a pair of electronic units connected by duplex multi-mode fiber optic cable at ports L1 and L2. **(The duplex fibers used with the CFL-4000 and CFL-5000 must be of equal length.)** The Medium/Full System pair, in addition to the duplex fiber, is also connected by a simplex multi-mode fiber optic cable at port L3. The Frame Grabber unit connects directly to the computer and the Camera unit connects directly to the digital camera, each with a 2 meter Camera Link MDR-26 male-to-male cable (both included).



Note: 350 meters (1150 feet) is the standard maximum distance for a 50/125, 1000 MHz-km fiber. See Appendix D for the maximum allowable distances of other fiber types.

1.2.1. Models Available from *Thinklogical*[™]

Part Number	Description
CFL-000S03-SCRX	Camera Fiberlink 3000, Frame Grabber, Single Mode, SC/APC
CFL-000S03-SCTX	Camera Fiberlink 3000, Camera, Single Mode, SC/APC
VOP-S05	Camera Fiberlink 3000 Optics Option for TX or RX, Single Mode, Dual Fiber, 10km
CFL-000M03-LCRX	Camera Fiberlink 3000, Base Frame Grabber Side, Multi-Mode, LC
CFL-000M03-LCTX	Camera Fiberlink 3000, Base Camera Side, Multi-Mode, LC
CFL-000M03-SCRX	Camera Fiberlink 3000, Base Frame Grabber Side, Multi-Mode, SC
CFL-000M03-SCTX	Camera Fiberlink 3000, Base Camera Side, Multi-Mode, SC
CFL-000M03-STRX	Camera Fiberlink 3000, Base Frame Grabber Side, Multi-Mode, ST
CFL-000M03-STTX	Camera Fiberlink 3000, Base Camera Side, Multi-Mode, ST
VOP-M04	Camera Fiberlink 3000 Optics Option for TX or RX, Multi-Mode, Dual Fiber, 50M, or 350M or 1000M, LC
VOP-M01	Camera Fiberlink 3000 Optics Option for TX or RX, Multi-Mode, Dual Fiber, 50M, or 350M or 1000M, SC OR ST
CFL-000S04-SCRX	Camera Fiberlink 4000, Full Frame Grabber, Single Mode, SC/APC
CFL-000S04-SCTX	Camera Fiberlink 4000, Full Frame Grabber, Single Mode, SC/APC
VOP-S05	Camera Fiberlink 4000 Optics Option for TX or RX, Single Mode, 3 Fibers, 10km
CFL-000M04-LCRX	Camera Fiberlink 4000, Full Frame Grabber Side, Multi-Mode, LC
CFL-000M04-LCTX	Camera Fiberlink 4000, Full Camera Side, Multi-Mode, LC
CFL-000M04-SCRX	Camera Fiberlink 4000, Full Frame Grabber Side, Multi-Mode, SC

CFL-000M04-SCTX	Camera Fiberlink 4000, Full Camera Side, Multi-Mode, SC
CFL-000M04-STRX	Camera Fiberlink 4000, Full Frame Grabber Side, Multi-Mode, ST
CFL-000M04-STTX	Camera Fiberlink 4000, Full Camera Side, Multi-Mode, ST
VOP-M05	Camera Fiberlink 4000 Optics Option for TX or RX, Multi-Mode, 3 Fibers, 50M, or 350M or 1000M, LC
VOP-M02	Camera Fiberlink 4000 Optics Option for TX or RX, Multi-Mode, 3 Fibers, 50M, or 350M or 1000M, SC OR ST
CFL-000S05-SCRX	Camera Fiberlink 5000, Industrial Frame Grabber, Single Mode, SC/APC
CFL-000S05-SCTX	Camera Fiberlink 5000, Industrial Frame Grabber, Single Mode, SC/APC
VOP-S08	Camera Fiberlink 4000 Optics Option for RX, Single Mode, 3 Fibers, 10km
CFL-000M05-LCRX	Camera Fiberlink 5000, Industrial Dual Base Frame Grabber Side, Multi-Mode, LC
CFL-000M05-LCTX	Camera Fiberlink 5000, Industrial Dual Base Camera Side, Multi-Mode, LC
CFL-000M05-SCRX	Camera Fiberlink 5000, Industrial Dual Base Frame Grabber Side, Multi-Mode, SC
CFL-000M05-SCTX	Camera Fiberlink 5000, Industrial Dual Base Camera Side, Multi-Mode, SC
CFL-000M05-STRX	Camera Fiberlink 5000, Industrial Dual Base Frame Grabber Side, Multi-Mode, ST
CFL-000M05-STTX	Camera Fiberlink 5000, Industrial Dual Base Camera Side, Multi-Mode, ST
VOP-M05	Camera Fiberlink 5000 Optics Option for TX or RX, Multi-Mode, 3 Fibers, 50M, or 350M or 1000M, LC
VOP-M02	Camera Fiberlink 5000 Optics Option for TX or RX, Multi-Mode, 3 Fibers, 50M, or 350M or 1000M, SC OR ST
CFL-000S06-SCRX	Camera Fiberlink 6000, High Speed Dual Base Frame Grabber, Single Mode, SC/APC
VOP-S15	Camera Fiberlink 4000 Optics Option for TX or RX, Single Mode, 4 Fibers, 10km

CFL-000M06-LCRX	Camera Fiberlink 6000, High Speed Dual Base Frame Grabber Side, Multi-Mode, LC
CFL-000M06-SCRX	Camera Fiberlink 5000, High Speed Dual Base Frame Grabber Side, Multi-Mode, SC
CFL-000M06-STRX	Camera Fiberlink 5000, High Speed Dual Base Frame Grabber Side, Multi-Mode, ST
VOP-S17	Camera Fiberlink 6000 Optics Option for TX or RX, Multi-Mode, 4 Fibers, 50M, or 350M or 1000M, LC
VOP-S16	Camera Fiberlink 6000 Optics Option for TX or RX, Multi-Mode, 4 Fibers, 50M, or 350M or 1000M, SC OR ST

All new products are designated with our
“Powered by **MRTS Technology**” logo.



Multi-Mode Fiber models are available in SC-, ST-, or LC-type fiber connectors.

Single-Mode Fiber models use APC (Angled Physical Contact) SC-type connectors.

To complement its line of Camera Fiber-Link extenders, *Thinklogical*[™] has also developed high performance **USB 2.0** and **Firewire 800** Camera Extenders. Please contact a *Thinklogical*[™] sales representative for details. (Please see the “How to Contact Us” section of this manual.)

1.2.2. Increased Security

Thinklogical's[™] Camera Fiber-Link Systems are designed for high-resolution camera extension applications. The ability to position the CPU away from cameras allows more control of your computer environment. This is especially important in applications where the cameras must be remotely located in harsh or industrial environments.

Remote Mounting

Each Camera Fiber-Link module can be used as a desk top or wall-mounted device. Mounting centers are provided with keyhole slots. (Orient the units with fiber cables and power connectors positioned upwards and MDR-26 connectors and RJ45 connector positioned downward.) A mounting template is provided in **Appendix D** for your convenience.

1.2.3. LASER Protection

The Camera Fiber-Link system is designed and identified as a **Class 1 LASER product**.

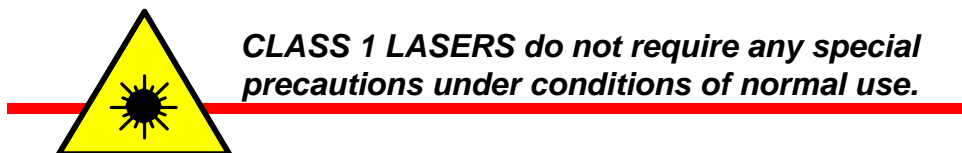

2. Product Features

2.1 System Features

Each Camera Fiber-Link system includes the following features:

- Supports all Camera-Link™ base (to full) configurations with pixel clocks 20– 85 MHz.
- Supports 1 dual-base or 2 individual-base cameras (CFL-5000 and CFL-6000)
- Fiber Count:
 - CFL-3000 – 2 fibers
 - CFL-4000 – 3 fibers
 - CFL-5000 – 3 fibers
 - CFL-6000 – 4 fibers
- Extend camera signals up to 350 meters (1150 feet) using standard multi-mode fiber
- Transparent Camera-Link™ operation
- Compact design: Units are self-contained and do not require user adjustments

HOUSING DIMENSIONS: 8.875 in. long x 5.44 in. wide x 1.19 in. high

(225.425 mm x 138.13 mm x 30.16 mm high)

- Signal transmission via fiber optic cable – no RF interference
- Serial Port (RJ45) with RS-232 Interface
- Class 1 laser product
- Screw lock (threaded) power connector
- Chassis ground post
- Compatible with user's own DC input
- Customer supplied power 5V-12V

Power Enhancement Kit (option)

- Customer supplied power 12V-24V

Industrial Enhancement Kit (option)

- DIN rail connectors for mounting

Indicator LEDs

- The **Green LED** near the power connector is lit when **appropriate power is connected** to the power in port.
- The **Red LED is lit solid** (near the camera link connectors) when there is a **loss of signal** on the fiber.
- The **Red LED blinks** if the fiber is **installed properly but there is no clock present** from the camera.
- When the **Red LED is off** the unit is **receiving appropriate signals**.

2.2. Hardware Features

2.2.1. CFL-3000

The **CFL-3000 Extender** supports the camera signals as well as the serial connections (both the SerTFG and SerTC within the MDR cable, and three pairs of RS-232 lines). The CFL-3000 supports Base configurations and requires two fibers. Each unit is housed in a compact metallic enclosure small enough to mount easily in cramped environments (7.00" x 5.44" x 1.19").



Figure 2: Top and side views of CFL-3000 Camera Side and Frame Grabber Side

2.2.2. CFL-4000

The **CFL-4000 Extender** supports the camera signals as well as the serial connections (both the SerTFG and SerTC within the MDR cable, and three pairs of RS-232 lines). The CFL-4000 supports Full/Medium/Base configurations and requires three fibers. Each unit is housed in a compact metallic enclosure small enough to mount easily in cramped environments (7.00” x 5.44” x 1.19”).

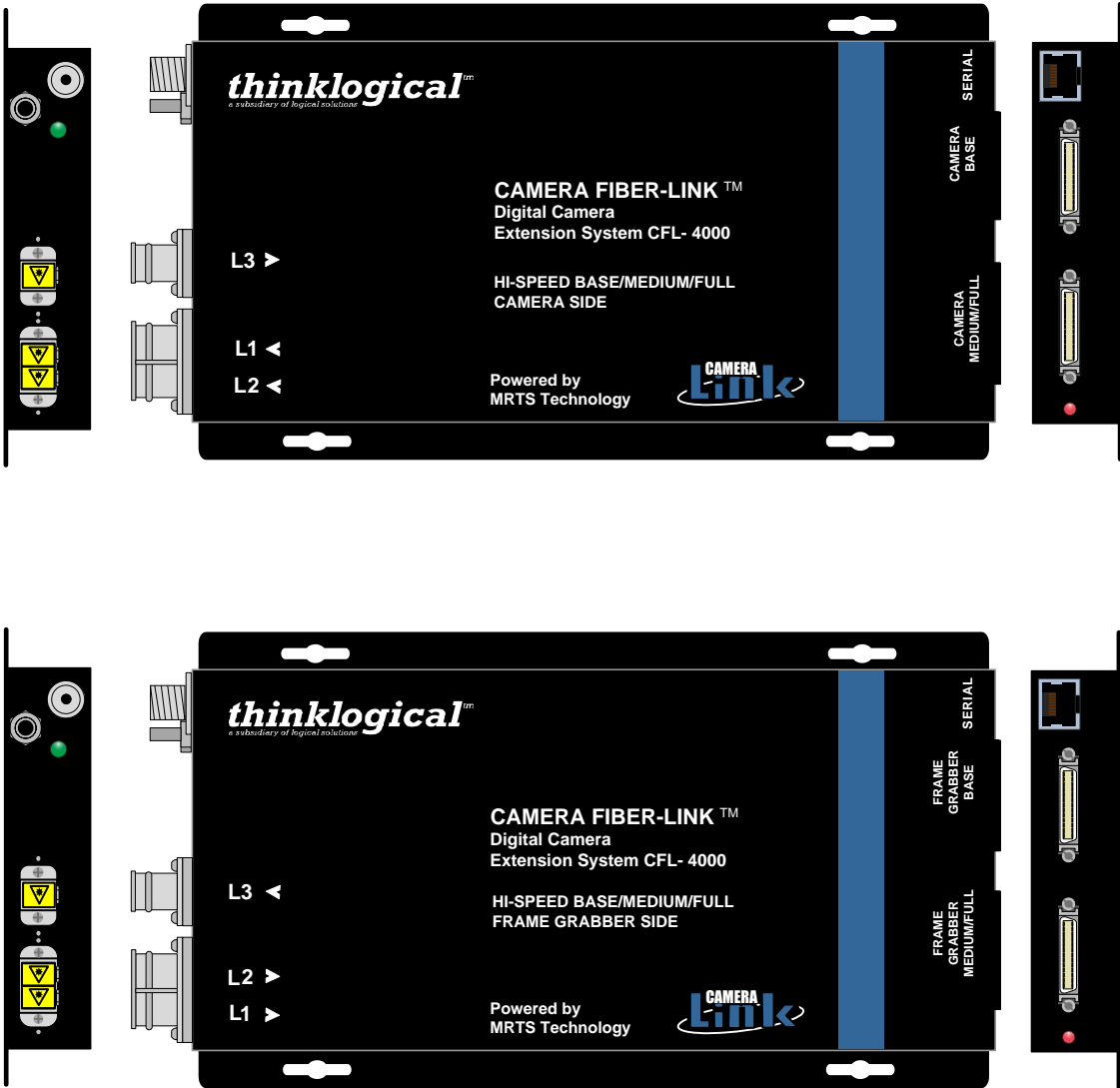

Figure 3: Top and side views of CFL-4000 Camera Side and Frame Grabber Side

2.2.3 CFL-5000

The **CFL-5000 Extender** supports the camera signals as well as the serial connections (both the SerTFG and SerTC within the MDR cable, and three pairs of RS-232 lines). The CFL-5000 supports one or two base Camera-Link™ cameras or one dual-base Camera-Link™ camera configurations.

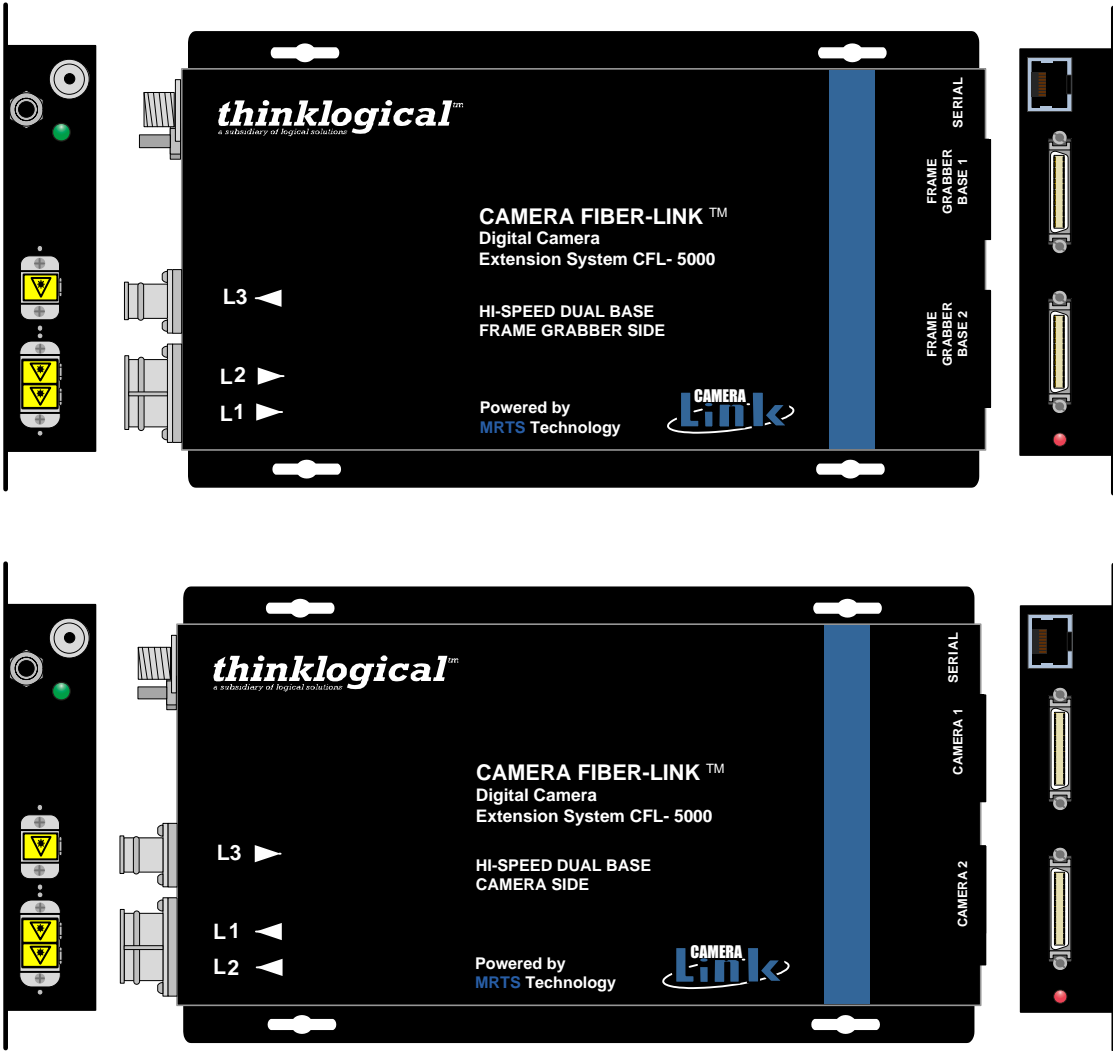

Figure 4: Top and side views of CFL-5000 Camera Side and Frame Grabber Side.

Each configuration requires three fibers. The CFL-5000 Camera Side receives data from each camera and converts the data into optical signals. These signals are sent to the CFL-5000 Frame Grabber Side transmitter, which in turn converts the optical signals into video data and sends them out to the one dual-base frame grabber (PC). Each unit is housed in a compact metallic enclosure small enough to mount easily in cramped environments (7.00” x 5.44” x 1.19”). The CFL-5000 is available with SC- (standard), ST- or LC-type fiber optic connectors.

2.2.4. CFL-6000

Thinklogical's™ **CFL-6000 Dual Camera Fiber-Link Receiver** is a unique component designed for users who have two cameras in different locations and where space is a concern. The Dual CFL-6000 RX receives optical data from two CFL-3000 Camera Side transmitters and converts them back into video data to send out to a frame grabber base.

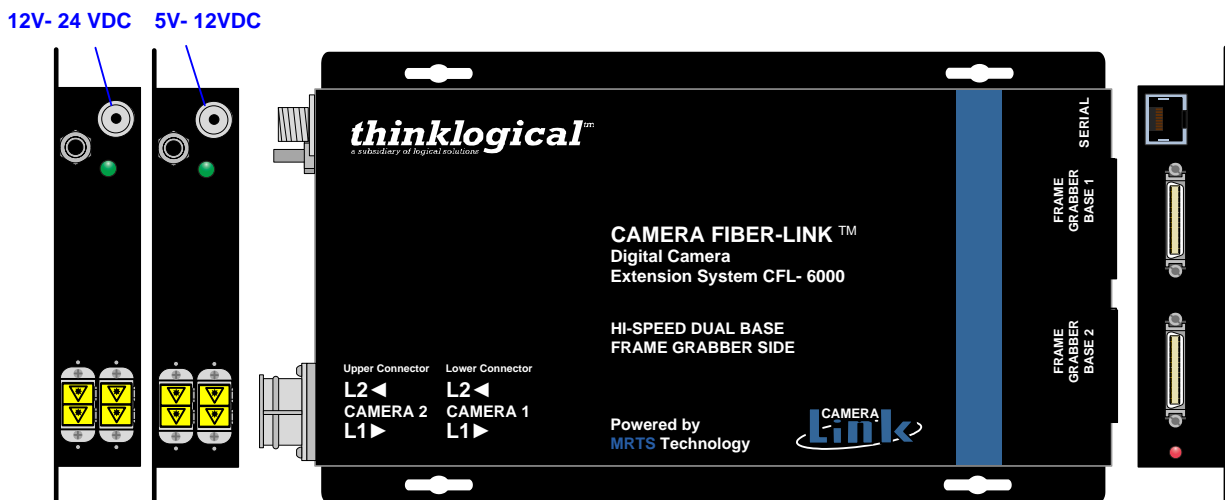

Figure 5: Top and side views of CFL-6000 Frame Grabber Side. The far left view shows the industrial enhancements (12V-24V Power) available.

2.2.5. Power Enhancement Kit (Optional)

The entire line of *Thinklogical™* Camera Fiber-Link Extenders features industrial enhancements, including a screw lock (threaded) input-power connector designed to meet the needs of a rugged industrial environment. The CFL-5000 and CFL-6000 models are available with input power ranges of 5-12V (standard) or 12-24V (industrial). Users can also choose to use their own DC input. A chassis ground post is included.

2.2.6 DIN Rails (Optional)

Each unit features DIN rail connectors for easy mounting, making it is possible to position your cameras in any setting, including hostile environments, while keeping the computer in a secure location. (A mounting template is included in *Appendix D*, for your convenience.)

<p>Optical Cable</p>	<p>Fiber Count: CFL-3000 (Base): 2 CFL-4000 (Full/Medium/Base): 3 CFL-5000 (Dual Base): 3 CFL-6000 (Dual Base RX): 4</p> <p>Fiber Type: Multi-mode, 50/125um or 62.5/125um SC-type connectors Fiber Connector Type: SC Standard / ST or LC Optional Maximum Fiber Distance: See Appendix C</p> <p>(Fiber Cable is either customer-supplied or can be ordered from <i>Thinklogical</i>[™])</p>
<p>LASER Output Specifications</p>	<p>850 nanometers</p>
<p>Operating Temp and Humidity</p>	<p>0 to 50 °C (32 to 122 °F), 5 to 95% RH, non-condensing</p>
<p>Pixel Clock</p>	<p>20 to 85 MHz</p>
<p>Bit Assignments</p>	<p>CFL-3000/CFL-5000/CFL-6000: Supports Base Configurations CFL-4000: Supports Full/Medium/Base Configurations</p>
<p>Camera/Frame Grabber Connector</p>	<p>CFL-3000: Camera Side -- (1) MDR-26 (supports Base only) Frame Grabber Side -- (1) MDR-26 (supports Base only) CFL-4000: Camera Side -- (2) MDR-26 (supports Full/Medium/Base) Frame Grabber Side -- (2) MDR-26 (supports Full/Medium/Base) CFL-5000: Camera Side -- (2) MDR-26 (supports Base only) Frame Grabber Side -- (2) MDR-26 (supports Base only) CFL-6000: Camera Side 1-- (1) MDR-26 (supports Base only) Camera Side 2 -- (1) MDR-26 (supports Base only) Frame Grabber Side -- (2) MDR-26 (supports Base only)</p>
<p>Dimensions</p>	<p>CFL-3000, CFL-4000, CFL-5000 and CFL-6000: Approx. 7.0" x 5.44" x 1.19" (177.80 x 138.13mm x 30.23mm)</p>
<p>Weights</p>	<p>Weight: 1 lb per unit Shipping Weight: 6 lbs</p>

Power Supply	<p>Standard 5V to 12V: Universal external power supply equipped with threaded screw lock connector for each side (supplied).</p> <p>Industrial 12V to 24V: Universal external power supply equipped with threaded screw lock connector for each side (supplied).</p>
AC Adapter	<p>Standard Version: Wall Mount (PWR-000022-R) Input 100-240VAC, 50-60Hz</p> <p>Industrial Version: Desktop (PWR-000033-R) Input 90-264VAC, 47-63Hz,</p>
DC Current	<p>Camera Side: 1.5A, steady state; 2.5A, peak</p> <p>Frame Grabber Side: 1.5A, steady state; 2.5A, peak</p>
AC Power Consumption	<p>Camera Side: Initial Power Draw: 10W Typical Input Power: 4.0W to 4.5W</p> <p>Frame Grabber Side: Initial Power Draw: 10W Typical Input Power: 3.75W to 4.5W</p>
Warranty	<p>12 months from date of purchase. Extended warranties available at time of purchase.</p>

Table 1: Technical Specifications

3. Connecting the Camera Fiber-Link

3.1 Types of Connections

3.1.1. Fiber Cable

A duplex fiber optic cable (Base version) or a duplex and a simplex fiber optic cable (Medium/Full version) will connect the Frame Grabber unit (near your CPU) and the Camera side unit (near the camera). The standard duplex multi-mode fiber cable must be 50 or 62.5 micron, terminated with an SC-, ST- or LC-type connector and no longer than 1150 running feet (350 meters). Be careful to not kink or pinch the fiber cable as it is being installed, and keep all bend radii to no less than 3 inches (76.2mm). Connect your fiber cable to the SC-type connector on each Camera Fiber-Link pair. Dress the cable so it will not get crushed, pinched or otherwise damaged.



Note: For CFL- 4000 and CFL- 5000 Units it is necessary that the multi-mode fiber on L1 and L2 to be of equal length.



Note: The Camera Fiber-Link is available with SC-, ST- or LC-type fiber connectors upon request.



Note: 350 meters (1150 feet) is the standard maximum distance for a fiber type of 50/125, 1000MHz-km. See *Appendix D* for maximum distances of other fiber types.

3.1.2. Digital Video Camera Side

The Camera Side unit connects to your video camera using an MDR-26 male-to-male cable (CBL-000007-002M) which is supplied with the system. The Base version includes one cable and the Medium/Full version includes two cables.

3.1.3. Digital Video Frame Grabber Side

The Frame Grabber Side unit connects to your controlling computer's Frame Grabber with an MDR-26 male-to-male cable (CBL-000007-002M) which is supplied with the system. The Base version includes one cable and the Medium/Full version includes two cables.

3.1.4. Serial Port

Both the Camera Side unit and the Frame Grabber Side unit have a serial port (RJ45 connector). This RS-232 interface connects to any external sensor, external lighting, etc., you may need using a CAT5 Cable Assembly (CBL-000001-002M) which is supplied with the system). A DB9M to RJ45F and a DB9F to RJ45F adapter is included with KIT-000033 (Fig. 6).

The serial port on the CFL-6000 system is different from the CFL-3000, CFL-4000, and CFL-5000 systems in that serial data from the PC is broadcast to both Camera Side units (transmitters). However, serial data to the PC only comes from Camera 1 on the Camera Side (transmitter 1).

Serial Port communications are sampled at approximately 32 MHz going from the Camera to Frame Grabber (RX, DSR, CTS)

Serial Port communications are sampled at 97 MHz going from the Frame grabber to the Camera (RTS, TX, DTX).

The pin-outs for the Serial Port (RJ45 connector) are as follows:

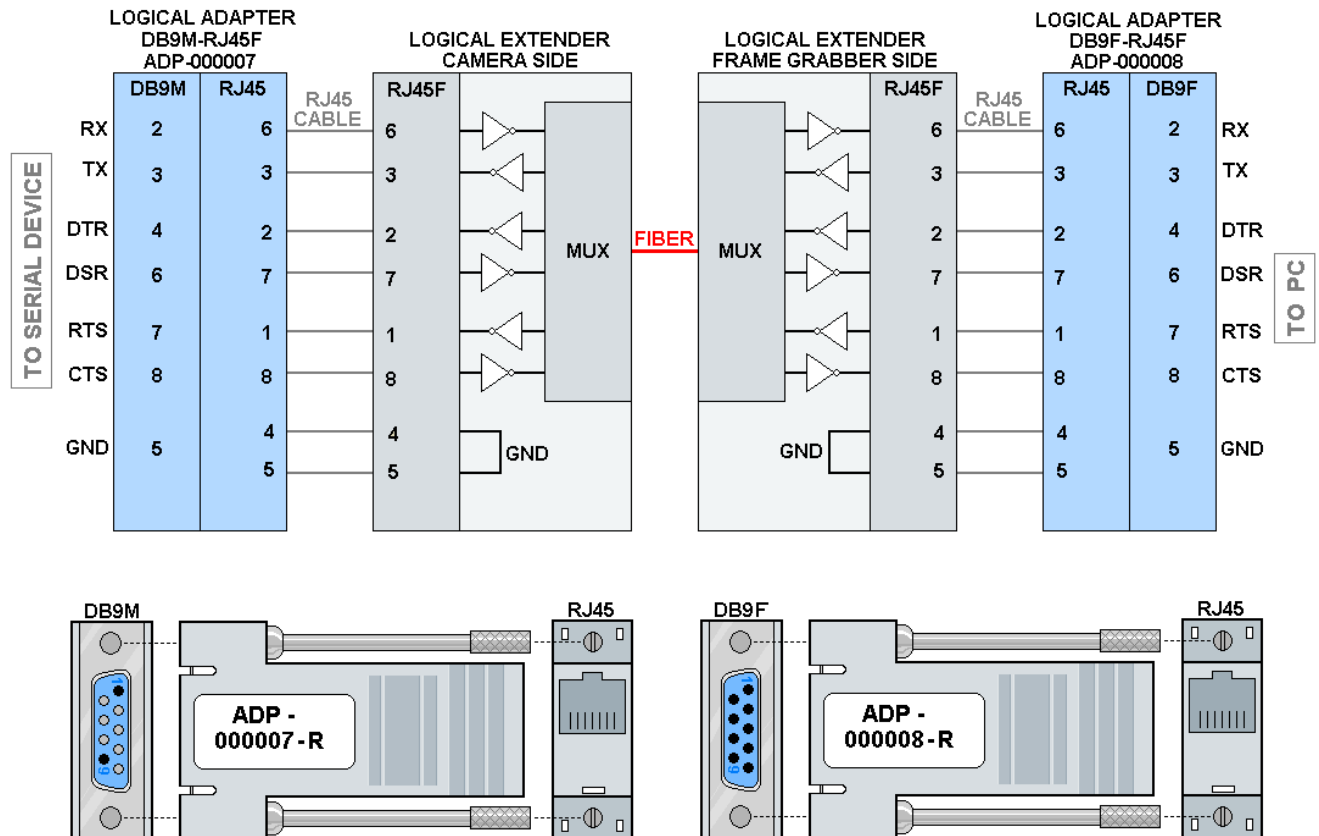

Figure 6: Diagram showing the serial connections used as data terminal connections and the included DB9 to RJ45 adapters. Other uses are also possible using each signal to control a function at the camera end, such as lighting, sensors, etc.

3.1.5. Camera Control

Communications from the Camera to the Frame Grabber, SerTFG—Differential pair with serial communications to the frame grabber, are sampled at 97 MHz.

Communications from the Frame Grabber to the Camera, SerTC—Differential pair with serial communications to the camera, are Sampled at 97 MHz.

Camera Control 1 (CC1), Camera Control 2 (CC2), Camera Control 3 (CC3) and Camera Control 4 (CC4) are sampled at 97 MHz.

3.2. AC Power

3.2.1. Standard Version : 5V-12V

Separate wall-pack AC-to-DC converters (Part Number PWR-000022-R) are included. A power jack is provided on both units and accepts the +5VDC input. The green power LED will light when the unit is receiving power.

The AC wall pack has a universal power rating (100-240 VAC, 50-60 Hz) and comes with slip-on interchangeable wall plugs for various AC power receptacles found throughout the world. Use the appropriate AC power wall plug for your country/location.



Figure 7: The Power Supply provided with each 5V–12V Camera Fiber-Link unit. International AC Power wall plug adapters are included with each power supply.

3.2.1.1. Industrial Version: 12V-24V

For the Industrial Power Input Option, separate desktop AC-to-DC converters (Part Number PWR-000033-R) are included. A power jack is provided on both units and accepts the +12VDC input. The green power LED will light when the unit is receiving power.

The AC desktop power pack has a universal power rating (90-264 VAC, 47-63 Hz) and is also supplied with a country-specific, industry standard AC Power Cord.

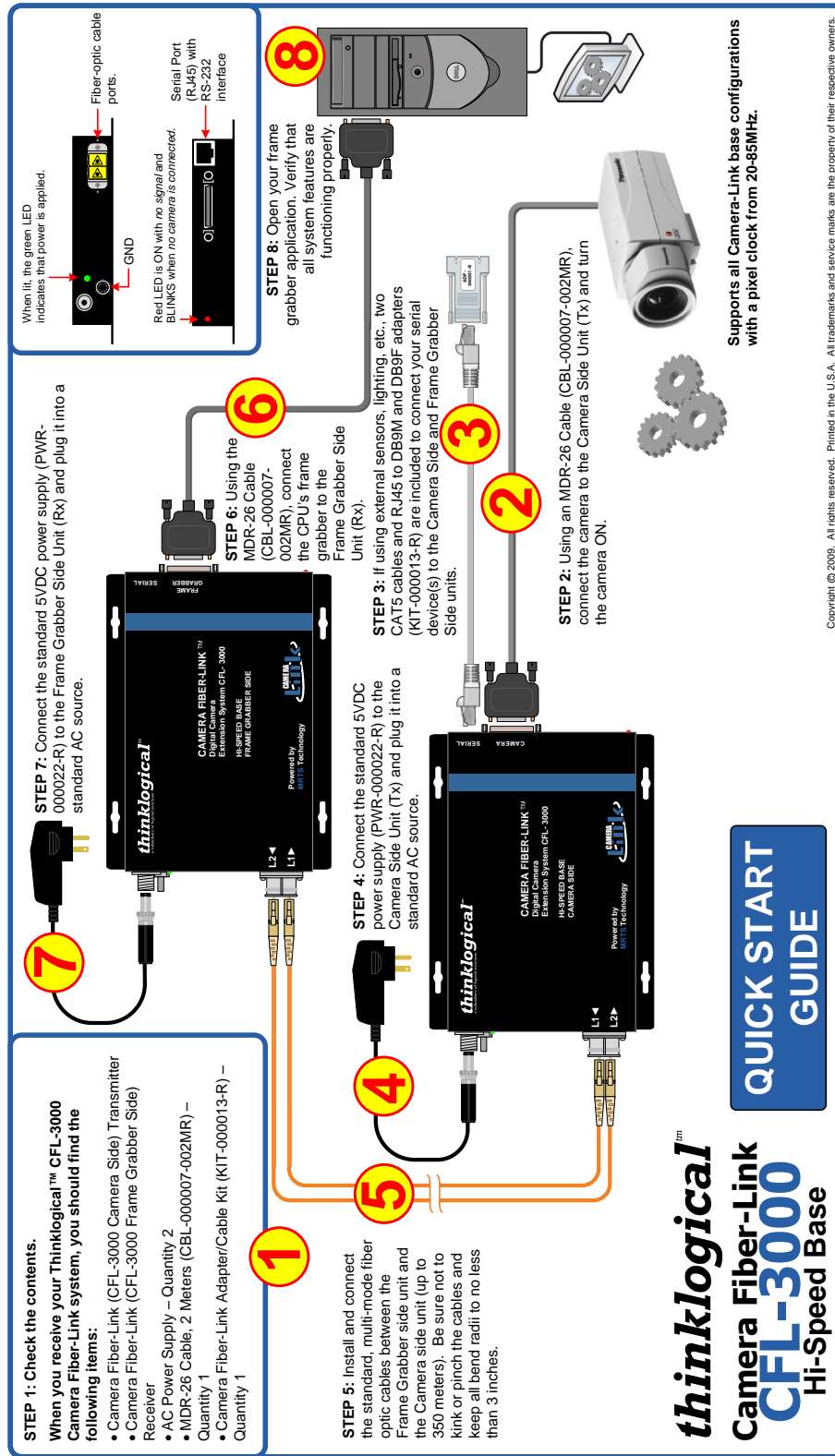

Figure 8: Two 12V–24V Desktop Power Supplies are provided with each Industrial Version Camera Fiber-Link System.

4. Order of Installation Events

The following pages contain Quick Start Guides for each of the four CFL models available from *Thinklogical*[™]. Each guide contains specific information about the contents of your Camera Fiber-Link System, as well as order of installation events and detailed connection instructions.

4.1. CFL-3000 (Figure 9)



4.2. CFL-4000 (Figure 10)

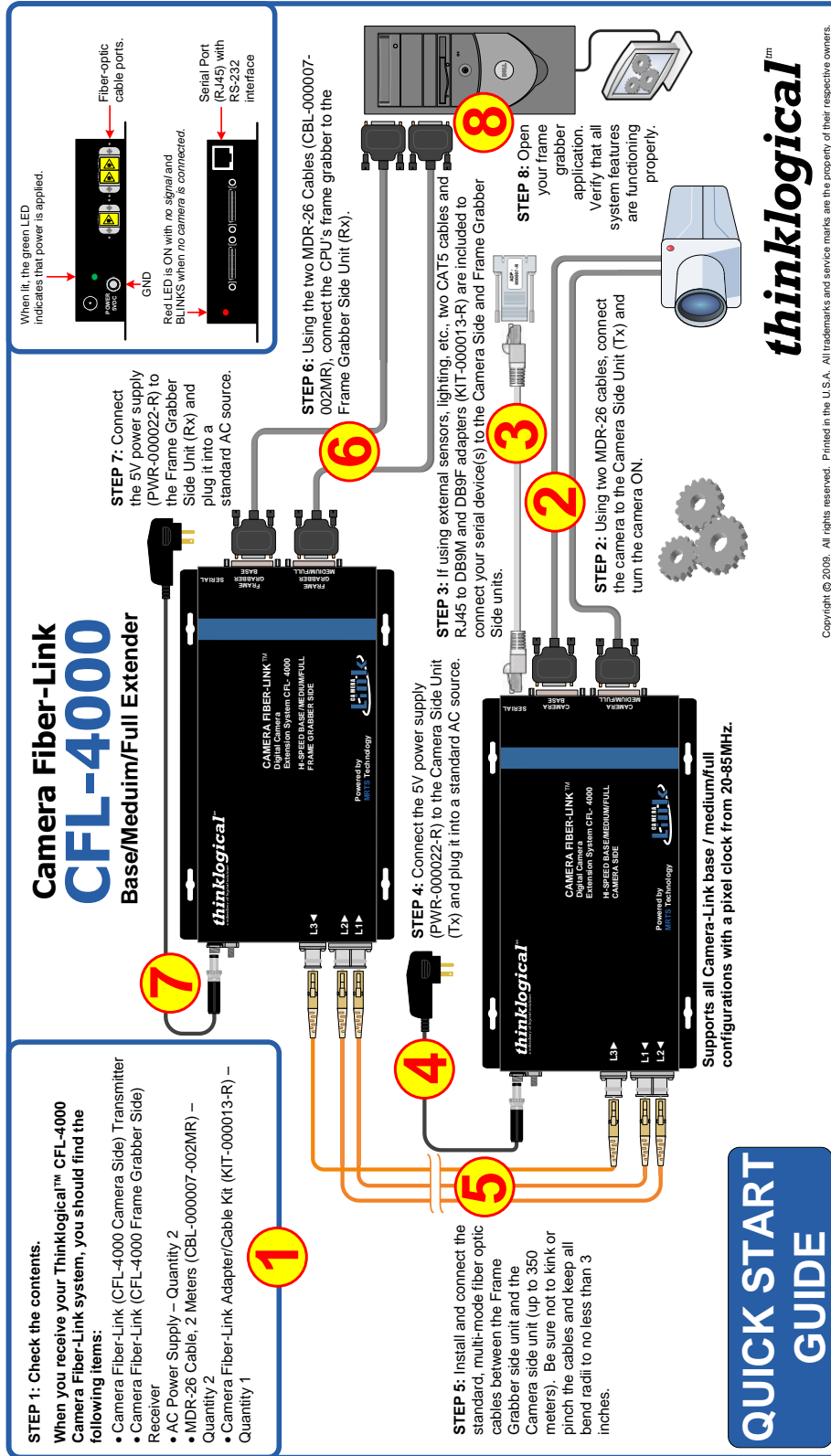

4.3 CFL-5000 (Figure 11)

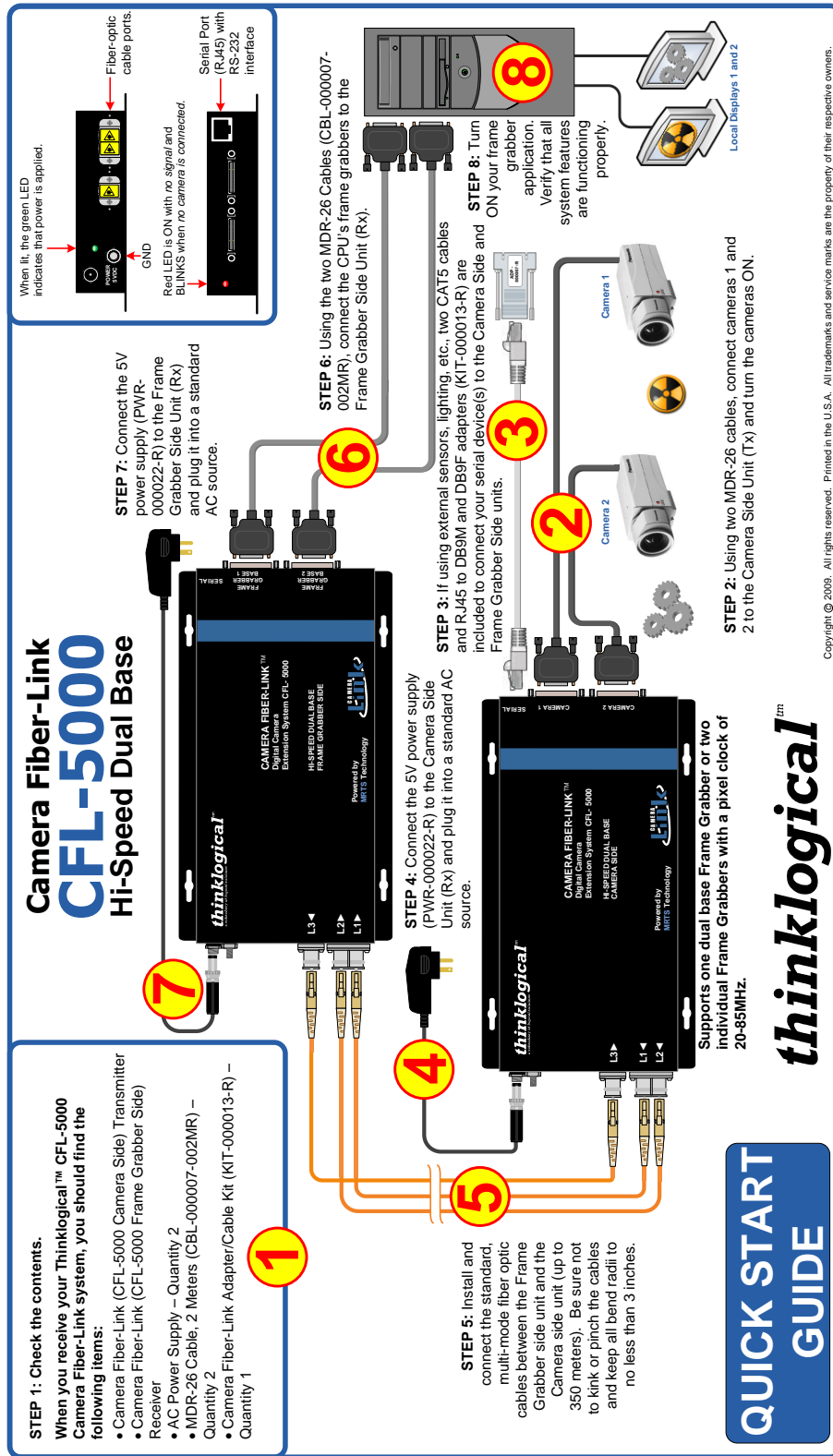

4.4. CFL-6000 (Figure 12)

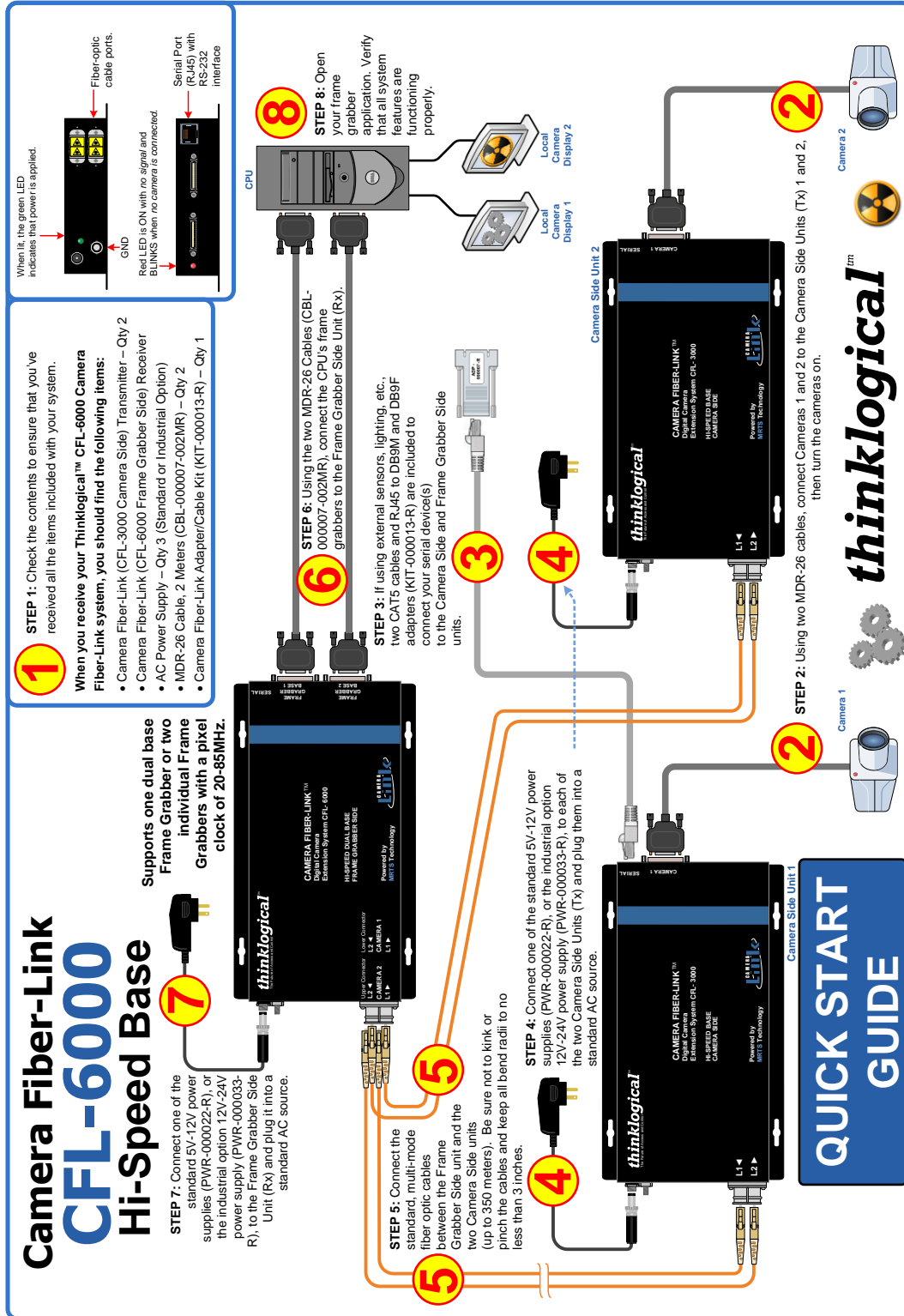

Copyright © 2009. All rights reserved. Printed in the U.S.A. All trademarks and service marks are the property of their respective owners.

5. Regulatory & Safety Compliance

The following Safety and Compliance declarations are pending approval.

5.1. Safety Requirements

5.1.1. Symbols found on the product

Markings and labels on our products follow industry-standard conventions. Regulatory markings found on the products comply with accepted industry requirements.

5.1.2. Product Serial Number

The Camera Fiber-Link products have a unique serial number imprinted on a small silver label that is placed on the bottom of the chassis. The serial number includes a manufacturer's date-code. The format for the date-code is 2-digits each for the month, the day and the year, and two or three digits for a unique unit number. This serial number is also found on the original shipping carton.

5.1.3. Connection to the Product

Connections and installation hardware for our products use industry-standard devices and methods. All wiring connections to the customers' equipment are designed to minimize proprietary or customized connectors or cabling. Power connections are made with regionally appropriate power cords and approved methods.

5.2 Regulatory Compliance

The *Thinklogical*[™] Camera Fiber-Link products are designed and made in the U.S.A. The Camera Fiber-Link products have been tested by a nationally recognized testing laboratory and found to be compliant with the following standards (both domestic USA and many international locations).



Warning! This is a Class 1 product. In a domestic environment this product may cause radio interference, in which case the user may be required to take adequate measures.

5.2.1. North America

These products comply with the following standards:

Safety

- UL60950 : 2000
- CAN/CSA C22.2 No. 60950-00

LASER Safety

- CDRH 21CFR 1040.10
- Class 1 LASER Product

Electromagnetic Interference

- FCC CFR47, Part 15, Class 1
- Industry Canada ICES-003 Issue 2, Revision 1

5.2.2. Australia & New Zealand

This is a Class 1 product. In a domestic environment this product may cause radio interference, in which case the user may be required to take adequate measures.

5.2.3. European Union

5.2.3.1. Declaration of Conformity

Manufacturer's Name & Address: **Thinklogical™**
100 Washington Street
Milford, Connecticut 06460 USA
Telephone (203) 647-8700

Product Name

Model: Camera Fiber-Link Video Extension System

These products comply with the requirements of the Low Voltage Directive 72/23/EEC and the EMC Directive 89/336/EEC.

5.2.3.2. Standards with Which Our Products Comply

Safety

- IEC60950:1992+A1, A2, A3, A4, A11

LASER Safety

- IEC60825:2001 Parts 1 and 2
- Class 1 LASER Product

Electromagnetic Emissions

- EN55022: 1994 (IEC/CSP1R22: 1993)
- EN61000-3-2/A14: 2000
- EN61000-3-3: 1994

Electromagnetic Immunity

- EN55024: 1998 Information Technology Equipment-Immunity Characteristics
- EN61000-4-2: 1995 Electro-Static Discharge Test
- EN61000-4-3: 1996 Radiated Immunity Field Test
- EN61000-4-4: 1995 Electrical Fast Transient Test
- EN61000-4-5: 1995 Power Supply Surge Test
- EN61000-4-6: 1996 Conducted Immunity Test
- EN61000-4-8: 1993 Magnetic Field Test
- EN61000-4-11: 1994 Voltage Dips & Interrupts Test

5.3. Supplementary Information

The following statements may be appropriate for certain geographical regions and might not apply to your location.



Note: This equipment has been tested and found to comply with the limits for a Class 1 digital device, pursuant to part 15 of the FCC Rules. These limits are designed to provide reasonable protection against harmful interference when the equipment is operated in a commercial environment. This equipment generates, uses, and can radiate radio frequency energy and, if not installed and used in accordance with the instruction manual, may cause harmful interference to radio communications. Operation of this equipment in a residential area is likely to cause harmful interference in which case the user may be required to correct the interference at their own expense.



Note: This Class 1 digital apparatus complies with Canadian ICES-003 and has been verified as compliant within the Class 1 limits of the FCC Radio Frequency Device Rules (FCC Title 47, Part 15, Subpart B CLASS 1), measured to CISPR 22: 1993 limits and methods of measurement of Radio Disturbance Characteristics of Information Technology Equipment.

This Class A digital apparatus meets all requirements of the Canadian Interference-Causing Equipment Regulations.

Cet appareil numérique de la classe A respecte toutes les exigences du Règlement sur le matériel brouilleur du Canada.

6. How to Contact Us

6.1. Customer Support

Thank you for choosing *Thinklogical*[™] products for your application. We appreciate your business and are dedicated to helping you successfully use our products. *Thinklogical*[™] is here to help you.

Thinklogical[™] is an engineering company and you will receive any information you may require directly from our most knowledgeable engineers. We believe that the first line of support is the design engineer that developed the product. Therefore, your questions will be handled promptly by our in-house engineers who are most familiar with your products.

To contact *Thinklogical*[™], use the following telephone numbers and internet-based methods.

6.1.1. Website

Check out our website for current product offerings, support information and general information about all of the products we offer.

Our internet website offers product information on all current systems, including technical specification sheets and installation guides (for viewing online or for download), product diagrams showing physical connections and other information you might need.

Internet: www.thinklogical.com



Note: Most online documents are stored as Adobe Acrobat “PDF” files. If you do not have the Adobe Acrobat reader needed to view PDF files, visit www.adobe.com for a download.

6.1.2. Email

Thinklogical[™] is staffed Monday through Friday from 8:30am to 5:00pm, Eastern Time Zone. We will try to respond to your email inquiries promptly. Please use the following email addresses for your specific needs:

- **info@thinklogical.com** – Information about *Thinklogical*[™] and our products.
- **sales@thinklogical.com** – Sales Department - orders, questions or issues.
- **support@thinklogical.com** – Product support, technical issues or questions, product repairs and request for Return Merchandise Authorization.

6.1.3. Telephone

- *Telephone Sales:* Contact our expert, technically knowledgeable sales staff via telephone in Milford, CT at **1-(203) 647-8700** or, if in the continental US, you may use our **toll-free number: 1-(800) 291-3211**. We are here Monday through Friday from 8:30am to 5:00pm, Eastern Time Zone. Ask for your representative's direct dial phone number when you call.
- *Telephone Product Support:* Contact our Product Support staff via telephone in Milford, CT at **1-(203) 647-8700**. The support lines are manned Monday through Friday, 8:30am to 5:00pm, Eastern Time Zone.
- *International Sales:* Please contact our US sales staff in Milford, CT at **1-(203) 647-8700**. We are here Monday through Friday, 8:30am to 5:00pm, Eastern Time Zone (same as New York City). If leaving a voice message, please provide a "best time to call back" so we may reach you at your convenience.

Our switchboard attendant will direct your call during regular business hours. We have an automated attendant answering our main telephone switchboard after regular business hours and holidays. You can leave voice messages for individuals at any time. Our sales representatives have direct numbers to speed up your next call to us.

6.1.4. Fax

Our company facsimile number is **1-(203) 783-9949**. Please indicate the nature of the fax on your cover sheet and provide return contact information.

6.2. Product Support

Thinklogical's[™] support personnel are available Monday through Friday from 8:30am to 5:00pm, Eastern Time Zone. If your application requires assistance at some time outside of our normal business hours, please contact us beforehand, if possible, and we will do our best to help you with your *Thinklogical*[™] products.

6.2.1. Limited Warranty Information

Thinklogical, LLC ("Thinklogical") warrants this product against defects in materials and workmanship for a period of one (1) year from the date of delivery (ordinary wear and tear excluded). This limited warranty does not cover defects resulting from (i) use of the product

other than as described in the applicable documentation for the product; (ii) modifications to or repairs of the product that are made by any party other than Thinklogical or a party acting on Thinklogical's behalf, or (iii) combination of the product with third party products that is not consented to by Thinklogical. Occurrences of events described in (i) – (iii) shall void the foregoing warranty. This warranty gives you specific legal rights, and you may also have other rights which vary from state to state.

Except for the express warranty set forth above, to the fullest extent permitted under applicable law, Thinklogical, LLC and its suppliers disclaim any and all other warranties, express and implied, including without limitation the implied warranties of merchantability, fitness for a particular purpose, title and non-infringement.

If the defective product is returned to the authorized dealer within one (1) year of the delivery date, repair or replacement of the product will be made. Repairs may be made with refurbished parts. If repair or replacement is not possible, Thinklogical may keep the defective product and refund the amount that you paid for the defective product. These are Thinklogical's sole obligations, and your exclusive remedies, for a breach of the limited warranty set forth above.

To return a defective product, contact the Thinklogical authorized dealer from whom you purchased the product. Do not return a product directly to Thinklogical without prior authorization from your dealer.

If you have received prior authorization from your dealer and are returning a product directly to Thinklogical:

1. Contact your sales representative, or call Customer Support at (800)291–3211 or + (203)647–8700.
2. Describe the defect with the product and Customer Support will issue a Return Merchandise Authorization Number (RMA#).
3. Pack the product in all of its original packing, if possible, and write the RMA number on the box.
4. Return the product to:
Thinklogical, LLC
Attn: RMA# [Insert the RMA# issued to you, by Thinklogical, here.]
100 Washington Street
Milford, CT 06460 USA

6.2.2. Our Address

If you have any issue with the product, have product questions or need technical assistance with your *Thinklogical*[™] system, please call us at **800-291-3211 (USA only)** or **(203) 647-8700** and let us help. If you'd like to write us, our mailing address is:

**Thinklogical[™] Inc.
100 Washington Street
Milford, CT 06460 USA**

Appendix A: Camera and Frame Grabber Compatibility Chart

**Cameras and Frame Grabbers Tested
with *Thinklogical*[™] Camera-Link Extender**

Manufacturer	Model	Bits/pixel	Taps	Clock (MHz)
Adimec	Adimec-1000m/S	8 or 10	1	40
Adimec	Adimec-1000m/D	8 or 10	2	40
Adimec	Adimec-1600m/S	8, 10 or 12	1	40
Adimec	Adimec-1600m/D	8,10 or 12	2	40
Adimec	Adimec-2000m/S	8,10 or 12	1	40
Adimec	Adimec-2000m/D	8,10 or 12	2	40
Adimec	Adimec-4000m/S	8,10 or 12	1	40
Adimec	Adimec-4000m/D	8,10 or 12	2	40
Adimec	Adimec-4020m/S	8, 10 or 12	1	40
Adimec	Adimec-4020m/D	8,10 or 12	2	40
Adimec	Adimec-1000c/S	8, 10 or 12	1	40
Adimec	Adimec-1000c/D	8, 10 or 12	2	40
Adimec	Adimec-1600c/S	8, 10 or 12	1	40
Adimec	Adimec-1600c/D	8, 10 or 12	2	40
Adimec	Adimec-2000c/S	8, 10 or 12	1	40
Adimec	Adimec-2000c/D	8, 10 or 12	2	40
Adimec	Adimec-4020c/S	8, 10 or 12	1	40
Adimec	Adimec-1000m/S	8 or 10	1	40
Atmel	AVIIVA C2 CL 4010	8 or 12	2	60
Atmel	AVIIVA SC2 CL 4010	8/10 or 12	2	60
Atmel	AViiVA M2 CL 0514	8/10 or 12	2	60
Atmel	AViiVA M2 CL 201x	8/10 or 12	2	60
Atmel	AViiVA M2 CL 4010	8/10 or 12	2	60
Atmel	AViiVA SM2 CL 0514	8/10 or 12	2	60
Atmel	AViiVA SM2 CL 201x	8/10 or 12	2	60
Atmel	AViiVA M4 CL 2014	8 or 12	2	60/120
Atmel	AViiVA M4 CL 6007	8 or 12	4	80/160
Atmel	AViiVA M4 CL 8007	8 or 12	4	80/160
Atmel	CAMELIA 8M C1	8/10 or 12	1	25
Atmel	CAMELIA 8M M1	8/10 or 12	1	25
Atmel	ATMOS 1M60	8/10 or 12	2	75
Atmel	ATMOS 1M30	8/10 or 12	2	37.5

**Cameras and Frame Grabbers Tested
with Thinklogical™ Camera-Link Extender**

Manufacturer	Model	Bits/pixel	Taps	Clock (MHz)
Basler	L103k	8 or 10	2	20 per tap
Basler	L301KC/F	8 or 10	1	60
Basler	A202K	10	2	40
Basler	A404K	8 or 10	8	50
Basler	A501k	8	1	50
Basler	A504KC	8	10	67
Cohu	7700	10	1	40
Cohu	7800	8	1	40
Cohu	7900	10	1	40
Chromasens	Aleos MCS 1k	8	1	60
Chromasens	Aleos MCS 2k	8	1	60
Chromasens	Aleos MCS 4k	8	1	60
Chromasens	Aleos MCS 7k	8	1	60
Dalsa	Dalstar DS-21-02M30	8 or 10	2	40 per tap
Dalsa	Dalstar DS-22-2M30	8 or 10	2	40 per tap
Dalsa	Falcon 1.4M100	8 or 10	2	80
Dalsa	Piranha2 P2-2X	8 or 10	2	40 per tap
Dalsa	Piranha Color 2K and 4K	24 or 36	3, 4, or 6	60 or 80
Dalsa	P2-4x-08k40	8 or 10	4	40
Dalsa	HS-40-04K40	8,12	4	40
Dalsa	HS-80-08K40	8,12	8	40
Dalsa	HS-80-08K80	8,12	8	40
Dalsa	HS-4X-02K30	8,10	4	30
Dalsa	Pantera SA 2M30 Camera DS-21-02M30 (1600x1200, mono)	8 or 10	2	40
Dalsa	Pantera SA 2M30 Camera DS-22-02M30 (1600x1200, color)	8 or 10	2	40
Dalsa	Pantera SA 2M30 Camera DS-24-02M30 (1920x1080, mono)	8 or 10	2	40
Dalsa	Pantera SA 2M30 Camera DS-25-02M30 (1920x1080, color)	8 or 10	2	40
Dalsa	Pantera SA 4M15 Camera DS-2x-04M15	8 or 10	2	40
Dalsa	Pantera TF DS-21-01M60	8,10,12	2	40
Dalsa	Pantera TF DS-1A-01M30	8,10,12	1	40
Dalsa	Pantera TF 11M4 PT-2x-11M04	8,10,12,14	2	36
Dalsa	Pantera TF 6M8 PT-2x-06M08	8,10,12,14	2	36

**Cameras and Frame Grabbers Tested
with Thinklogical™ Camera-Link Extender**

Manufacturer	Model	Bits/pixel	Taps	Clock (MHz)
Dalsa	PT-21-04M30	10	2	40
Dalsa	PT-21-04M60	10	4	40
Dalsa	P2-4X	8 or 10	4	40
Dalsa	P2-80-12K40	8	8	40
Dalsa	P3-80-XX	8,12	8	40
Dalsa	S2-1X-XX	8 or 10	1	40
Dalsa	P2-42-06K40	8	4	40
GOODRICH / Sensors Unlimited	SU320KT	12	1	24.4
GOODRICH / Sensors Unlimited	SU320KTX	12	1	24.4
GOODRICH / Sensors Unlimited	SU3420KTS	12	1	24.4
GOODRICH / Sensors Unlimited	SU320KTSW	12	1	24.4
GOODRICH / Sensors Unlimited	SU640SDV	14	1	43.956
GOODRICH / Sensors Unlimited	SU640SDX	14	1	43.956
GOODRICH / Sensors Unlimited	SU640SDW	14	4	43.956
GOODRICH / Sensors Unlimited	SU640SDSE	14	1	43.956
GOODRICH / Sensors Unlimited	SULDV-512LX	14	4	40
GOODRICH / Sensors Unlimited	SULDV-256LX	14	2	40
GOODRICH / Sensors Unlimited	SULDV-512LD	14	2	40
GOODRICH / Sensors Unlimited	SULDV-256LS	14	2	40
GOODRICH / Sensors Unlimited	SULDV-1024LE	14	2	40
GOODRICH / Sensors Unlimited	SULDV-512LSI	14	2	40
Imperx	IPX-VGA90	8 or 10	1	40
Imperx	IPX-VGA120	8 or 10	1	40
Imperx	IPX-VGA210	8 or 10	2	40
Imperx	IPX-1M48	8 or 10	2	40
Imperx	IPX-2M30	8 or 10	2	40
Imperx	IPX-2M30H	8 or 10	2	40
Imperx	IPX-4M15	8 or 10	2	40
Imperx	IPX-11M5	8 or 10	2	28
Imperx	MDC-1004	12	2	40
Imperx	MDC-1600	12	2	40
Imperx	MDC-1920	12	2	40
Imperx	MDC-2048	12	2	40
Imperx	MDC-4000	12	2	28

**Cameras and Frame Grabbers Tested
with Thinklogical™ Camera-Link Extender**

Manufacturer	Model	Bits/pixel	Taps	Clock (MHz)
JAI	CV-A10CL	8 or 10	1	36.15
JAI	CV-A20CL	8 or 10	1	60
JAI	CV-A70CL	8 or 10	1	36.15
JAI	CV-L107CL	8 or 10	2	40
JAI	CV-M2CL	8 or 10	1	40
JAI	CV-M7+CL	8 or 10	1	40.49
JAI	CV-M71CL	8 or 10	1	36.5
JAI	CV-M8CL	8 or 10	1	40
JAI	CV-M9CL	8 or 10	2	33.75
MIKROTRON	MC1302/03	8 or 10	2	66
MIKROTRON	MC1310	8	8	85
MIKROTRON	MC1310/11	8	8	85
Photonfocus	MV-D752-160-CL-8	8	2	80
Photonfocus	MV-D1024-160-CL-8	8	2	80
PCO	pco.1200	10	2	80
PCO	pco.2000	14	2	80
PCO	pco.4000	14	2	80
Pulnix	TM-1020-15CL	8 or 10	1	20
Pulnix	TM-1325CL	8 or 10	1	27.5/55
Pulnix	TM-1402CL	8 or 10	1	25/50
Pulnix	TM-2016-8CL	8 or 10	1	20
Pulnix	TMC-4100CL	8 or 10	1	40
Pulnix	TM6710CL	8 or 10	1	25.49
Pulnix	TM-6730CL	8 or 10	1	12.5
Pulnix	TM-6740CL	8 or 10	1	40
Pulnix	TM-6760CL	8 or 10	1	12.5 or 25
Pulnix	TM-9730CL	8 or 10	1	14.32
Pulnix	TMC-1325CL	8 or 10	1	27.5 or 55
Pulnix	TMC-1402CL	8 or 10	1	25 or 50
Pulnix	TMC-4100CL	8 or 10	1	40
Pulnix	TMC-6730CL	8 or 10	1	12.5
Pulnix	TMC-6740CL	8 or 10	1	40
Pulnix	TMC-6760CL	8 or 10	1	12.5 or 25
Pulnix	TMC-9730CL	8 or 10	1	14.32

**Cameras and Frame Grabbers Tested
with Thinklogical™ Camera-Link Extender**

Manufacturer	Model	Bits/pixel	Taps	Clock (MHz)
Redlake	MegaPlus II ES 11000	24bit RGB	3	25
Redlake	ES 2020	8,10 or 12	2	30/38
Redlake	ES 1603	8,10 or 12	1	12-Oct
Redlake	ES 4020	8,10 or 12	2	30/38
Redlake	ES 3200	8,10 or 12	1	12-Oct
Redlake	ES 1100	8,10 or 12	2	30/38
Redlake	ES 2001	8,10 or 12	2	30/38
Redlake	ES 2020	8,10 or 12	1 or 2	30/38
Redlake	ES 1603	8,10 or 12	1	10 or 12
Redlake	ES 4020	8,10 or 12	1 or 2	30/38
Redlake	ES 3200	8,10 or 12	1	10 or 12
Redlake	ES 1100	8,10 or 12	1 or 2	30/38
Redlake	ES 2001	8,10 or 12	1 or 2	30/38
Silicon Imaging	SI-1280	12	1	40
Sony	XCL-U1000	10	1	36
Sony	XCL-U1000C	24bit RGB	1	36
Sony	XCL-V500	10	1	24.5
Sony	XCL-X700	10	1	29.5
Toshiba	1K-SX1	8	1	28.634
SVS-Vistek	SVS 085CFCL	10	1	43

Discontinued Cameras Supported

Manufacturer	Model	Bits/pixel	Taps	Clock (MHz)
Dalsa	1m28	10	1	28
Dalsa	1M28/75/150-SA	8	2	40
JAI	CV-A33CL	8 or 10	1	40
JAI	CV-M4+CL	8 or 10	1	40.49
JAI	CV-M7	8 or 10	1	40.49
Pulnix	TMC-1000-CL	24bit RGB	3	20
Pulnix	TMC-1400-CL	8	1	50
Pulnix	TM-4000-CL	8 or 10	1	40
Pulnix	TMC-4000-CL	8 or 10	1	40

Tested Frame Grabbers

Manufacturer	Model
Active Silicon	Phoenix PHX-D48CL
Bitflow	R3-PCI-CL13
Bitflow	R3-PCI-CL23
Bitflow	R64=PCI-CL-D
Bitflow	R64=PCI-CL-F
Bitflow	R64-PCE-CL-D
Bitflow	R64-PCE-CL-F
Coreco Imaging	PC-Camlink
Coreco Imaging	X64-CL Dual
Datacube	MaxRevolution V2-1000 Full
Dalsa	X64 Xcelera-CL PX4 Dual
Dalsa	X64 Xcelera-CL PX4 Full
Euresys	Grablink Value
Imperx	FrameLink
Matrox	Meteor II CL
Matrox	Helios XCL
Matrox	ODYSSEY XCL
Matrox	ODYSSEY XPRO
Matrox	SOLIOS XLC
Mikrontron	INSPECTRA-4C
Mikrontron	INSPECTRA-5
National Instruments	NI 1428 CL
National Instruments	NI 1426 CL
National Instruments	NI 1429 CL
SILICON-SOFTWARE	microEnable III
SILICON-SOFTWARE	microEnable III-XXL
SILICON-SOFTWARE	microEnable IV
SILICON-SOFTWARE	microEnable IV-FULL x4

Appendix B: DB9/RJ45 Adapter Pin-outs

Below are the pin-outs for the listed adapters ADP-000007-R and ADP-000008-R:

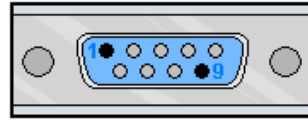

ADP-000007-R

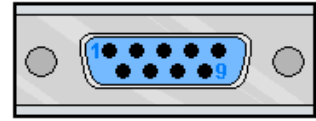

ADP-000008-R

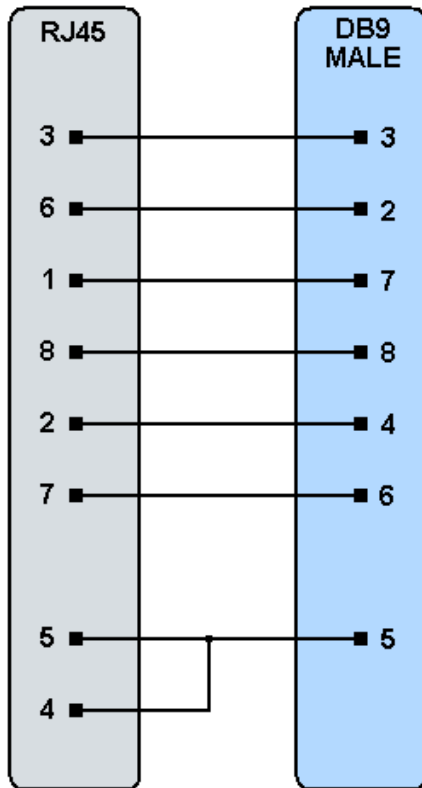

RJ45F to DB9M adapter for SCS/CFL

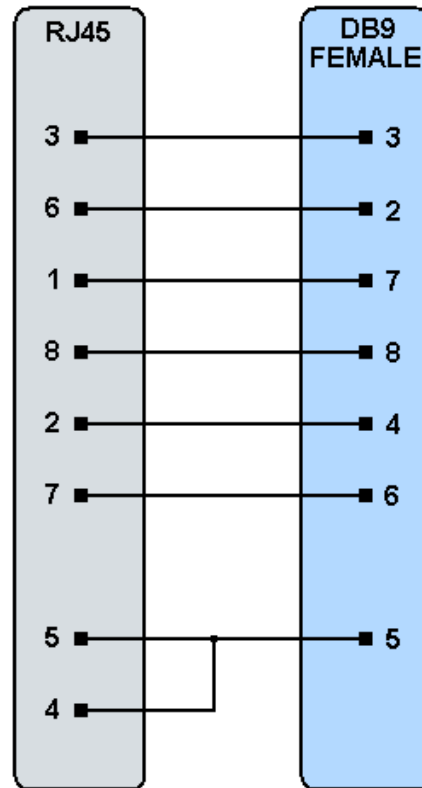

RJ45F to DB9F adapter for SCS/CFL

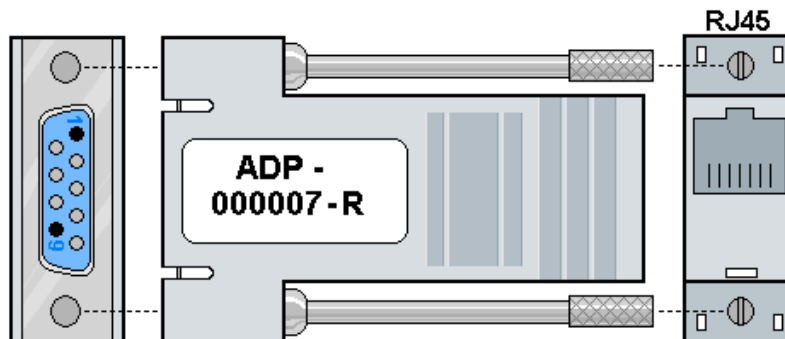

Appendix C: Maximum Distances for Fiber Types

Camera Fiber-Link Extender distance from camera to host computer, tested as a full configuration:

<u>Fiber Type</u>	<u>Distance</u>
OM1	50m
OM2	350m
OM3 Enhanced	1000m
SMF	80km



Note: The maximum fiber length is tested as one continuous fiber with no junctions, patch panels, etc.

Appendix D: Camera Fiber-Link Mounting Template

Each Camera Fiber-Link module can be used as a desk top or wall-mounted device. Mounting centers are provided with keyhole slots. (*Orient the units with fiber cables and power connectors positioned upwards and MDR-26 connectors and RJ45 connector positioned downward.*) Users may choose the most appropriate fasteners and anchors to mount each unit according to the requirements of each application.



Note: Be sure to leave adequate clearance (3 inch minimum bend radius) for your Fiber Cable.

Housing Dimensions:

7.0 in. long x 5.44 in. wide x 1.19 in. high
(177.80 mm x 138.13 mm x 30.16 mm high)

The following page contains an actual-size template that is valid for each of the Camera Fiber-Link units available from *Thinklogical*[™]. You can print a 1:1 copy of this page to help you position and mount your device. Vital dimensions are shown in inches and [millimeters].



Note: Only the following template (pg. 37) should be used for positioning your *Thinklogical*[™] Camera Fiber-Link device. Other graphic depictions of the devices in this document are not to scale.



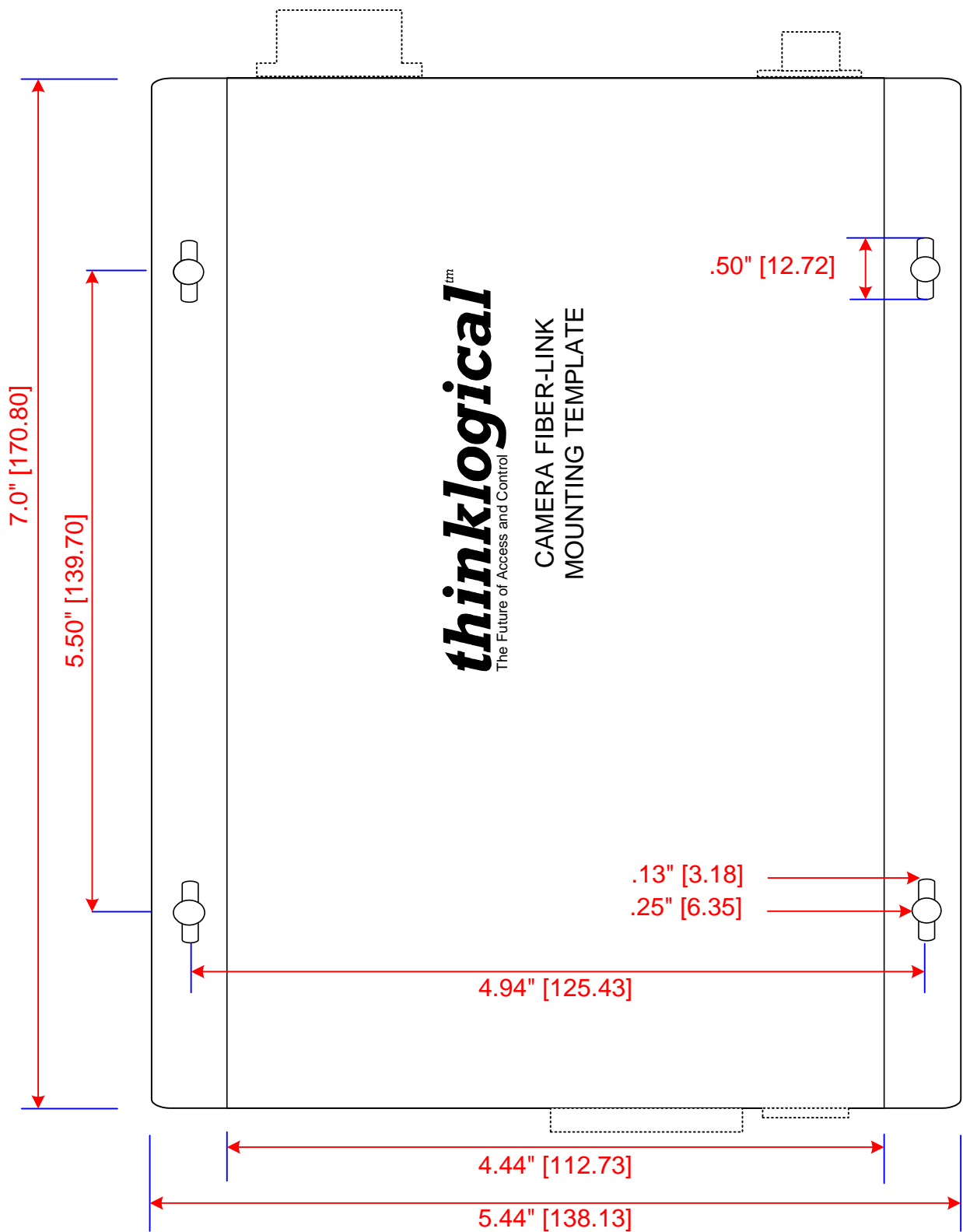

Figure 13: CFL Mounting Template