

DCS DIGITAL CROSS-POINT SWITCH QUICK START GUIDE

DCS-72 Video Chassis

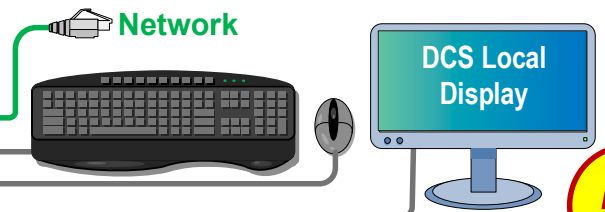
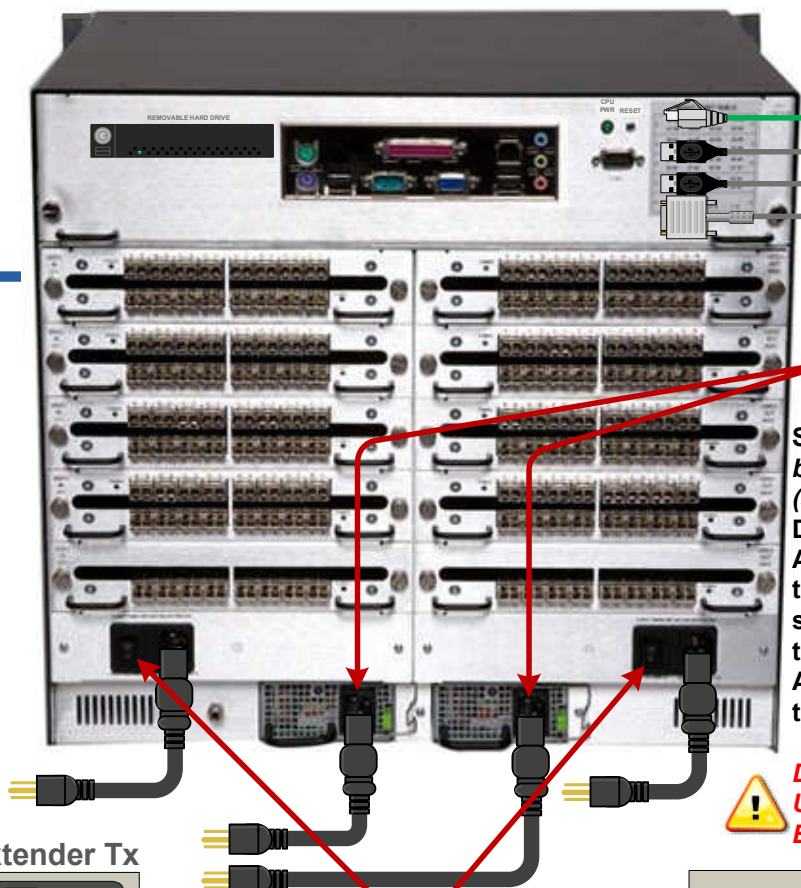

STEP 5: Connect an active network cable, local display and KMASS devices to the DCS CPU.
NOTE: The Removable Hard Drive located on the CPU is only operational in the "locked" position. (2 keys are included.)

5

4

STEP 4: Ensure that both fans are ON (step 3). Install the DCS's two supplied AC power cords into the two power supplies and plug them into a standard AC source to turn the unit ON.
DO NOT RUN THE UNIT WITHOUT BOTH FANS ON!

1

STEP 1: Connect the video and KMASS devices at the Receiver. Install the Receiver's supplied AC power cord and turn the unit ON.

2

STEP 2: Connect your multi-mode fiber-optic cables between the Receiver and the DCS OUT ports. For KMASS fibers, connect the transmit fiber L2 of the Receiver to an R (receive) connector and the receive fiber L1 to a T (transmit) connector on the KMASS card.

3

STEP 3: Plug both fans into a standard AC source and put both fan switches in the ON (1) position.

6

STEP 6: Connect your multi-mode fiber-optic cables between the Transmitter and the DCS IN ports. For KMASS fibers, connect the transmit fiber L1 of the Transmitter to an R (receive) connector and the receive fiber L2 to a T (transmit) connector on the KMASS card.

7

STEP 7: Connect the display and KMASS devices at the Transmitter. Install the Transmitter's supplied AC power cord and turn the unit ON. Turn the CPU ON and verify that all system functions are working properly.

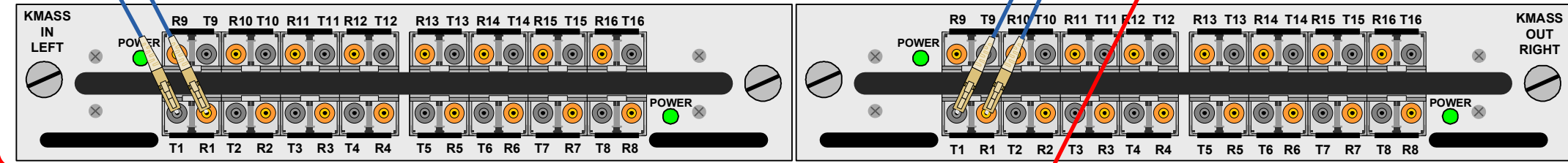
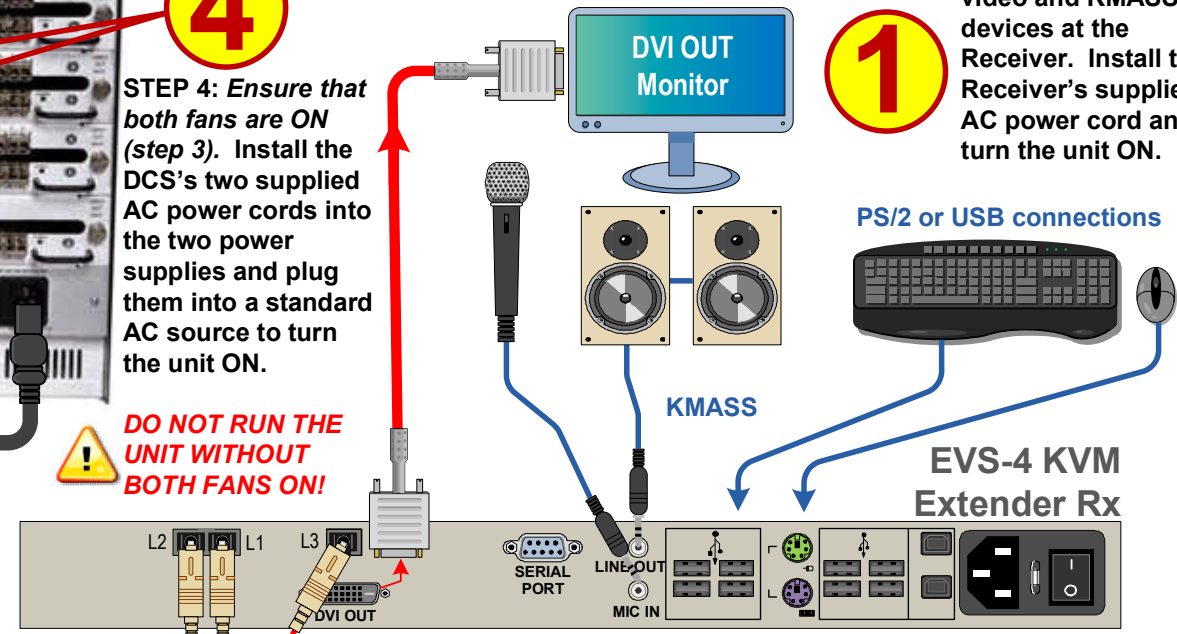
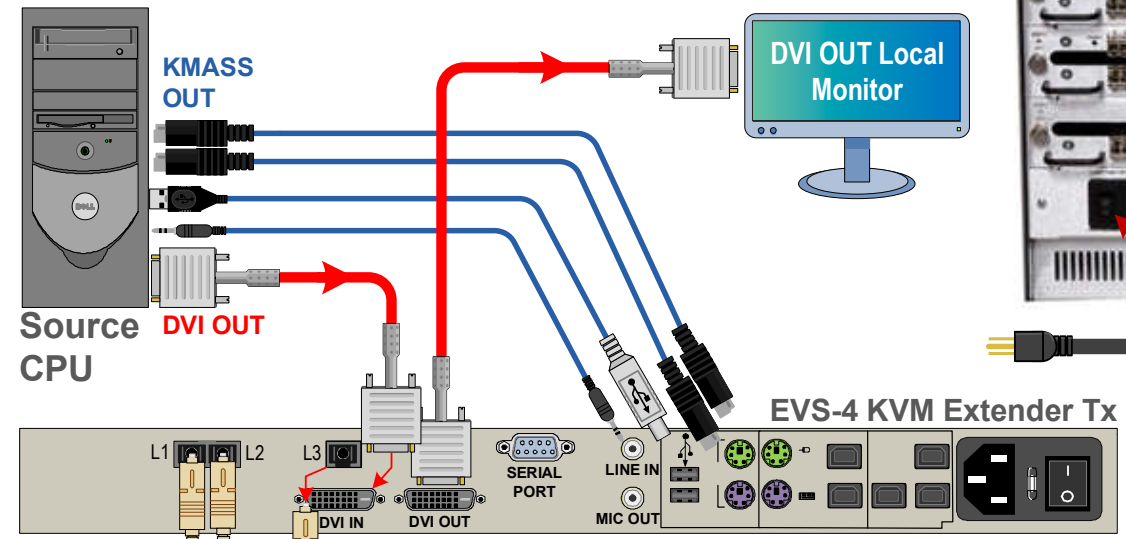

DCS KMASS Chassis

DCS KMASS Chassis INPUT/OUTPUT Cards.

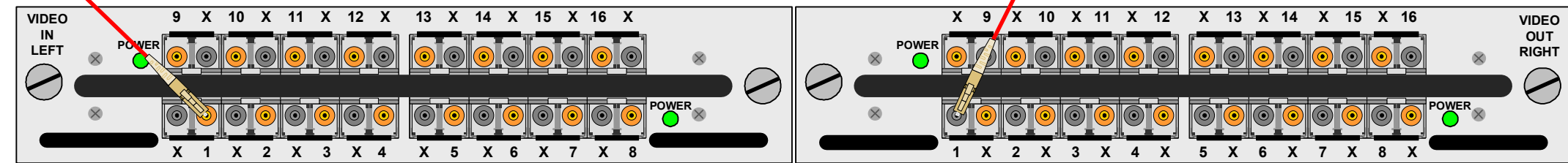

DCS Video Chassis

DCS Video Chassis INPUT/OUTPUT Cards.

The Thinklogical™ Digital Cross-point Switch is an electrical to optical and optical to electrical switch used exclusively with Thinklogical™ KVM extenders. Multimode fiber(s) connect the Input/Output modules of the DCS to any of the Thinklogical™ KVM extenders.

Available models include the DCS-32, DCS-72 and DCS-144.



PHONE: (800) 291-3211
 WEBSITE: www.thinklogical.com
 EMAIL: support@thinklogical.com

Visit us online at www.thinklogical.com for more product information, current updates and the complete line of Thinklogical™ products.

Copyright © 2009. All rights reserved. Printed in the U.S.A. All trademarks and service marks are the property of their respective owners. DCS_Video&KMASS_Quick_Start_Rev_B